



# Pressure Independent Control Valve

***Nexus Valve***  
*Vivax*



# Table of contents

## Chapter NexusValve Vivax DN 15L-50H

<b>1.</b>	<b>Safety instructions</b>	<b>4</b>
1.1	Rules/regulations	4
1.2	Intended use	5
1.3	Initial operation	5
1.4	Working on the system	5
1.5	Liability	5
<b>2.</b>	<b>Introduction</b>	<b>6</b>
2.1	Description	6
2.2	Benefits	6
2.3	Design	7
2.4	Flow setting	8
2.5	Actual flow versus differential pressure verification	10
2.6	Mounting	11
2.7	Flow control accuracy	14
2.8	Energy efficiency example	15
2.9	Actuators	17
2.10	NexusValve Vivax T	17
2.11	Flushing the system	20
2.12	Shut-off damper	20
2.13	Operation	21
<b>3.</b>	<b>Applications</b>	<b>23</b>
<b>4.</b>	<b>Product data sheet</b>	<b>25</b>
4.1	Product finder	25
4.2	NexusValve Vivax DN 15-50	26
4.2.1	DN 15-32 female/female	26
4.2.2	DN 40-50 female/female	28
4.2.3	NexusValve Vivax T DN 15-25 with temperature limiter / sensor	29
4.3	Flow diagrams	31
4.4	Measuring signal diagrams	38
<b>5.</b>	<b>Accessoires</b>	<b>42</b>
<b>6.</b>	<b>Sizing examples</b>	<b>44</b>
6.1	NexusValve Vivax system sizing	44
6.2	General specifications DN 15L-50H	47

<b>7.</b>	<b>Actuators</b>	<b>48</b>
7.1	Thermoelectric Actuator for NexusValve Vivax DN 15-25	48
7.1.1	Description	48
7.1.2	Benefits	48
7.1.3	Design	49
7.1.4	Modulating actuator 24 V	50
7.1.5	Modulating actuator 24 V with feedback signal	52
7.1.6	ON/OFF actuator 230 V and 24 V	54
7.2	Electromechanical actuator for NexusValve Vivax DN15-32	56
7.2.1	Description	56
7.2.2	Benefits	56
7.2.3	Design	57
7.2.4	Installation	57
7.2.5	Modulating actuator 24 V	59
7.2.6	3 point floating actuator 24V	60
7.3	Electromechanical actuator for valves DN 15-32	62
7.3.1	Description	62
7.3.2	Benefits	62
7.3.3	Design	63
7.3.4	Installation	65
7.3.5	Modulating actuator 24 V	67
7.4	Electromechanical Actuator for NexusValve Vivax DN 40-50	68
7.4.1	Description	68
7.4.2	Benefits	68
7.4.3	Design	69
7.4.4	Installation	70
7.4.5	Modulating actuator 24 V	71
7.4.6	ON/OFF actuator 230 V	72
7.4.7	ON/OFF actuator 24 V	73

# 1. Safety instructions

**Please read the instructions carefully before installation**

The installation and initial operation of the assembly may be carried out only by an authorised specialist company.

Prior to starting work, familiarise yourself with all parts and how they are handled.

The application examples in these operating instructions are ideas sketched out. Local laws and regulations have to be observed.

**Target group:**

**These instructions are intended for authorised specialists exclusively.** Work on the heating system, the potable water as well as gas and power network may be carried out by specialists only.



**Please follow these safety instructions carefully in order to avoid hazards and damage to people and property.**

## 1.1 Rules/regulations

Please observe the applicable accident prevention regulations, the environmental legislation and the legal rules for mounting, installation and operation. Moreover, please observe the appropriate guidelines of German standard DIN, EN, DVGW, VDI and VDE (including lightning protection) as well as all current relevant country-specific standards, laws and regulations. Old and newly enforced regulations and standards shall apply, if they are relevant for the individual case. Moreover, the regulations of your local energy supply company have to be observed.

**Electrical connection:**

**Electrical wiring work may be carried out by qualified electricians only. The VDE regulations and the specifications of the relevant energy supply company have to be met.**

**Excerpt:****Installation and construction of heat generators as well as the drinking water heaters:**

DIN EN 4753, Part 1: Water heater and water heating plants for potable and process water.

DIN EN 12828 Heating systems in buildings.

Allowed medium (cf. DIN EN 12828): Heating water according to VDI 2035 (non-corrosive), water-glycol mixtures with up to max. 50% glycol content.

DIN 18 421: Insulation work on technical plants

AV B Wa s V Regulations concerning the general conditions for the supply with water

DIN EN 806 ff.: Technical rules for potable water installation

DIN 1988 ff.: Technical rules for potable water installation (national addition)

DIN EN 1717: Protection of potable water against contaminations

DIN 4751: Safety equipment

**Electrical connection:**

VDE 0100: Erection of electrical equipment, grounding, protective conductor, potential equalisation conductor.

VDE 0701: Repair, modification and testing of electrical devices.

VDE 0185: General aspects on the erection of lightning protection systems.

VDE 0190: Main potential equalisation of electrical plants.

VDE 0855: Installation of antenna plants (shall apply mutatis mutandis).

**Additional remarks:**

VDI 6002 Sheet 1: General principles, system technology and use in house building

VDI 6002, Sheet 2: Use in students' hostels, retirement homes, hospitals, indoor swimming pools and on camping facilities

**Caution:**

**Prior to any electrical wiring work on pumps and controls, these modules have to be disconnected from voltage correctly.**

## 1.2 Intended use

Inexpert installation as well as use for a purpose not intended of the assembly shall rule out all warranty claims.

All shut-off valves may be closed by an approved specialist only in case of servicing as otherwise the safety valves are not effective.



**Do not modify the electrical components, the construction or the hydraulic components! You will impair the safe function of the plant otherwise.**

## 1.3 Initial operation

Prior to the initial operation, the plant has to be tested for tightness, correct hydraulic connection as well as accurate and correct electrical connection. In addition, the plant has to be flushed correctly and/as required in keeping with German standard DIN 4753. The initial operation has to be carried out by a trained specialist, which has to be recorded in writing. In addition, the settings have to be put down in writing.

The technical documentation has to be available at the device.

## 1.4 Working on the system

**The plant has to be de-energised and to be checked for the absence of voltage (such as on the separate fuse or a master switch). Secure the plant against unintentional restart.**

(If gas is used as fuel, close the gas shut-off valve and secure against unintentional opening.) Repair work on component parts with a safety-relevant function is impermissible.

## 1.5 Liability

We reserve all copyrights for this document. Wrongful use, in particular reproduction and forwarding to third parties shall not be permitted.

These installation and operating instructions shall have to be handed to the customer. The executing and/or authorised tradesperson (such as fitter) shall have to explain the function and operation of the plant to the customer in an intelligible manner.

## 2. Introduction



### 2.1 Description

The NexusValve Vivax valve is a combined pressure independent flow limiter and control valve which maintains a constant flow independently of pressure changes in heating or cooling systems.

Installed with an actuator the NexusValve Vivax combines an automatic flow limiter and a two-way control valve. Having full control authority the valve reacts instantly and adjusts the flow according to the Building Management System (BMS) or room thermostat signal.

Without actuator the NexusValve Vivax works as an automatic flow limiter. In this way the valve ensures the design flow in terminal units. The NexusValve Vivax valve also prevents overflows in the systems at any time.

### 2.2 Benefits

- Automatic balancing
- Direct flow measuring of actual flow by the use of built-in Fluctus nozzle
- Easy system error detection by actual flow verification
- Always 100% valve authority for perfect flow control as full stroke is independent of pre-setting
- Installation in any position and directly onto bends, reducers and flexible pipes
- No overflows and no unnecessary energy consumption
- Better thermal comfort
- High flow control accuracy with only  $\pm 7\%$  tolerance
- Commissioning not needed
- Easy valve selection
- Colour coded flow control devices for easy identification
- Easy system flushing due to removable flow control device
- Low installation cost due to the two in one – motorized valve and automatic flow limiter – construction
- Precise pump tuning for improved energy saving when verifying flow via measuring points
- System extension or repair possible without altering the flow in the already operating terminal units
- Single unit housing, not susceptible to pipes tension, eliminates risk of water leakage from the valve

## 2.3 Design

The NexusValve Vivax valve consists of a pre-setting unit performing like a manual balancing valve, a two-way motorized valve, a thermoelectric or electromechanical actuator, a differential pressure regulator, measuring points, a Fluctus orifice and a valve housing.

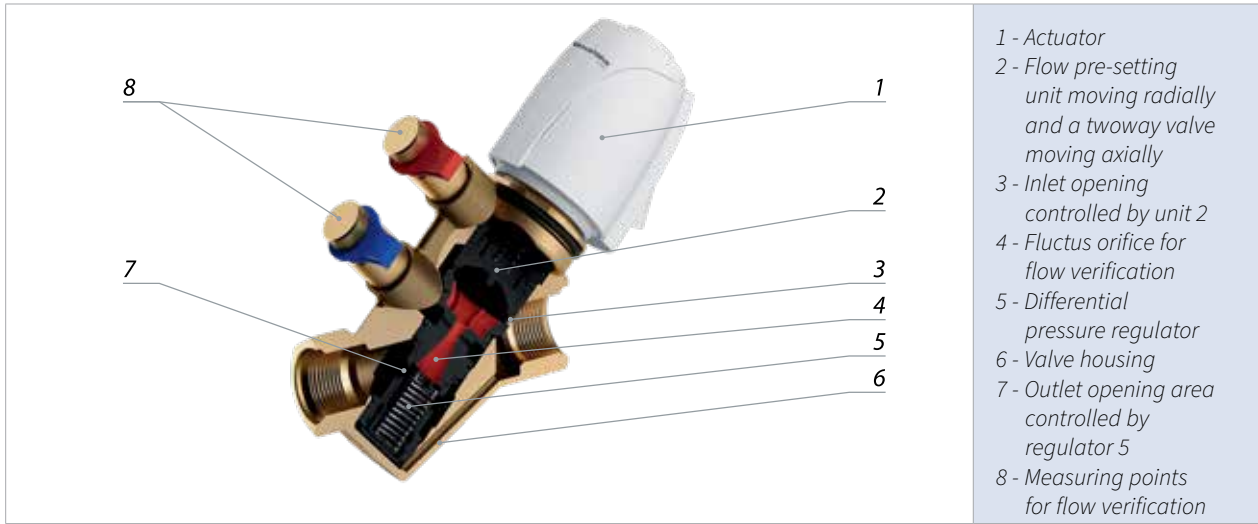

The internal valve parts are designed as one flow control device unit. This enables removal of the complete flow control device for easy system flushing. After the flow control device is removed, a blind cap (also used as the flow pre-setting tool) is mounted to seal the housing when flushing.



The pre-setting unit of the flow control device ensures the design flow and at the same time it operates as a two-way valve, controlled by the actuator in reference to the BMS system or room thermostat signal.

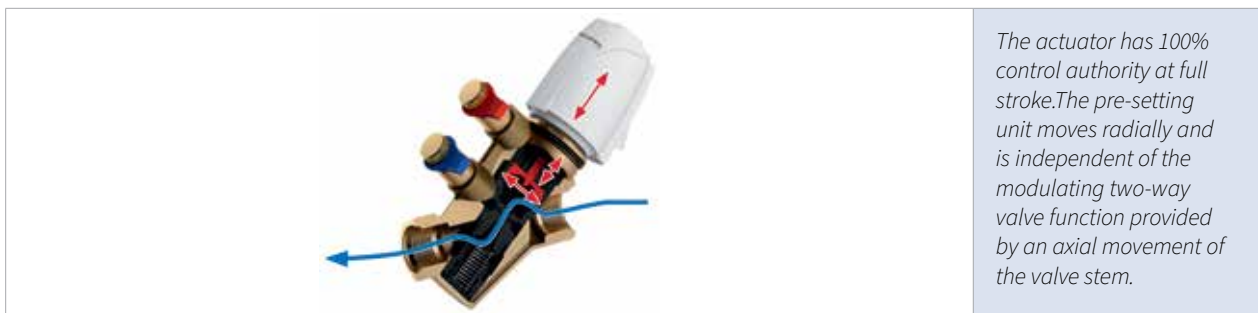

## 2. Introduction

As the pre-setting unit moves radially and the two-way valve function is provided by the axial movement of the same item, the actuator has full stroke, regardless of the pre-setting. The integrated regulator maintains constant differential pressure across the pre-setting unit and the two-way valve. The required flow is thereby kept constant regardless of pressure fluctuations in the system. This provides 100% control authority in all situations. When the actuator changes the position of the two-way valve in response to a signal from the BMS system or a room thermostat, a new inlet opening area is established and a new flow achieved. Due to the differential pressure regulator operation the flow is again kept constant.

### 2.4 Flow setting

Before setting the design flow on the NexusValve Vivax, the pump must be set at maximum capacity and all service valves in the system must be in fully open position. The differential pressure across the NexusValve Vivax must at all times not exceed 400 kPa. The design flow is easily adjusted with the enclosed pre-setting tool. After connecting the NexusValve Balancing Computer, or any other flowmeter, to the NexusValve Vivax, the flow reading is provided for precise flow tuning. The pre-setting tool is mounted on top of the valve covering the valve stem. The scale on the pre-setting tool is read against the marking on the brass housing of the valve.



*NexusValve Vivax with pre-setting tool mounted.*

The flow is set by turning the pre-setting tool from 0-90°. Each marking on the scale indicates a step of 10%. When the required flow is set and the starting differential pressure is provided, the flow is kept constant by the NexusValve Vivax valve.



*NexusValve Vivax at:  
A - 100% pre-set flow  
B - 50% pre-set flow*



A unique feature of the NexusValve Vivax valve is the integrated Fluctus nozzle which enables direct flow measurement. This provides an exact flow setting of the valve and makes verification of the actual flow rate possible at any time for correct documentation. System troubleshooting thereby also becomes considerably easier which saves time.

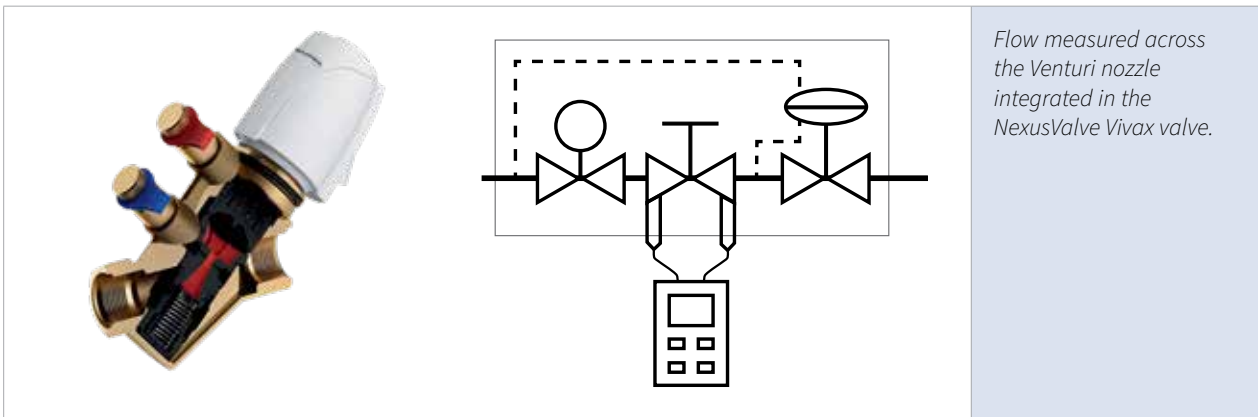

To verify the flow a flowmeter is connected to the measuring points of the NexusValve Vivax. The fixed Kvm value of the integrated Fluctus nozzle is then typed into the flowmeter to directly display the actual flow at an accuracy tolerance of  $\pm 3\%$ . When the required flow is set, the balance in the system is provided. The flow is kept constant by the NexusValve Vivax valve regardless of pressure fluctuations.

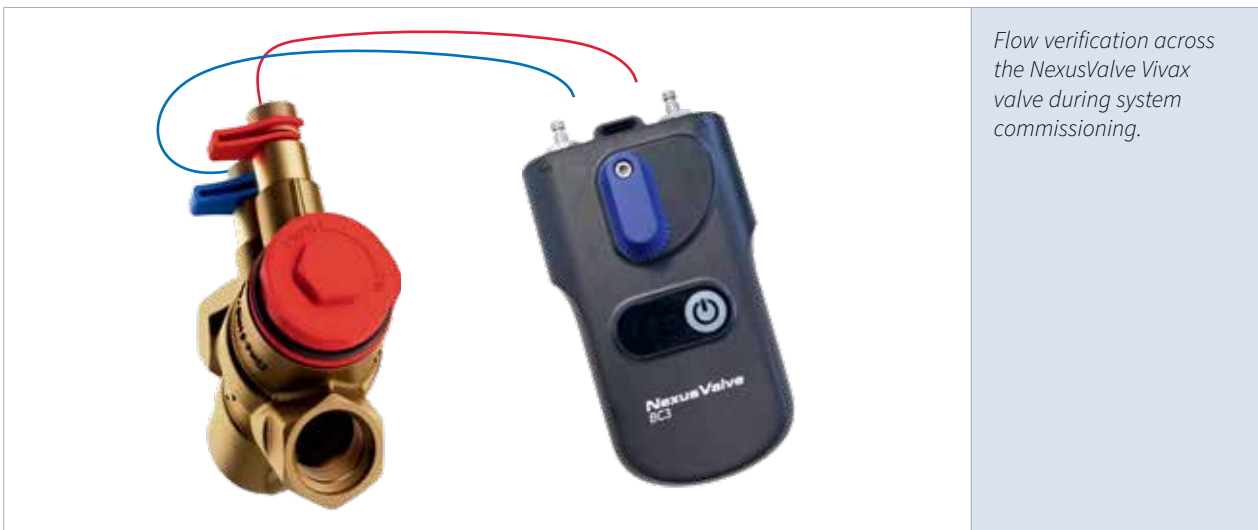

## 2. Introduction

### 2.5 Actual flow versus differential pressure verification

To verify if the valve maintains a constant flow two different methods can be used. The first method is based on actual flow measuring across the built-in Fluctus nozzle – as used in the NexusValve Vivax. In the second method only the differential pressure is measured across the valve to verify if the integrated differential pressure regulator operates within its working range – flow reading is not available.

The direct reading of the actual flow has proved to be advantageous compared to the differential pressure measuring across the valve. The main reason is that the actual flow distribution in all the terminal units can be verified, this is particularly useful during system commissioning if the correct flow distribution is not obtained and the problem is to be identified. This is not possible when using the method of differential pressure measuring across a valve and for this reason extra measuring orifices must be installed to check the actual flow.

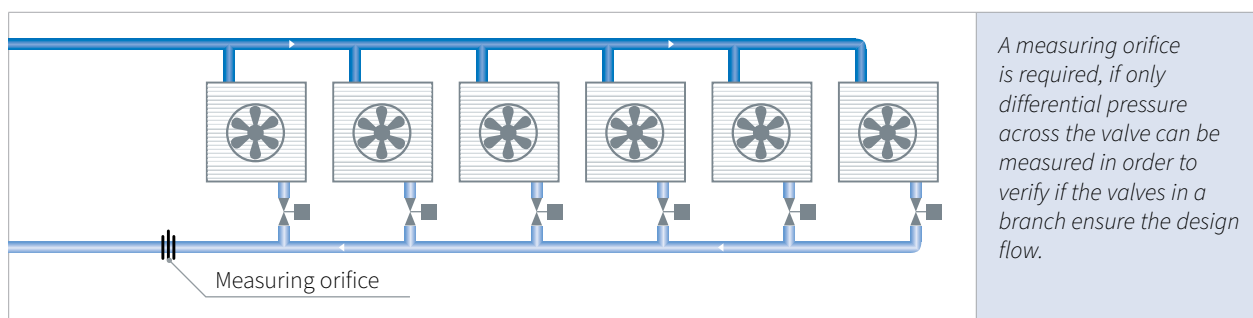

When measuring the differential pressure only, the problem can be that debris in the system water can get stuck in the valve causing a wrong differential pressure reading. The flowmeter will in this instance show that the differential pressure required for dynamic flow control is obtained, but in reality the flow is not ensured as the valve is clogged. As the NexusValve Vivax valve has a direct read-out of the actual flow, it will show during commissioning if debris is blocking the flow control device. In this case the flow control device is to be removed, cleaned and reinserted after which the flow verification is repeated. This does not have any impact on the remaining valves as the NexusValve Vivax is pressure independent.

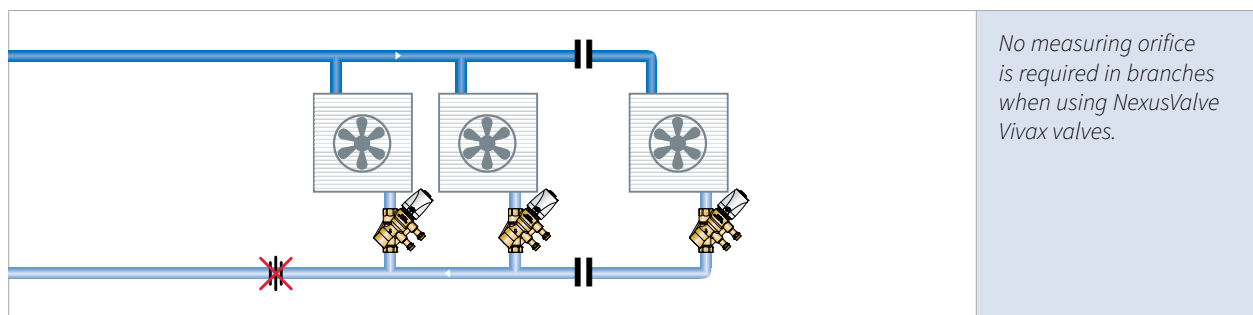

No installation of measuring orifices is with the NexusValve Vivax valve needed as the flow can be verified directly across the valve.

## 2.6 Mounting

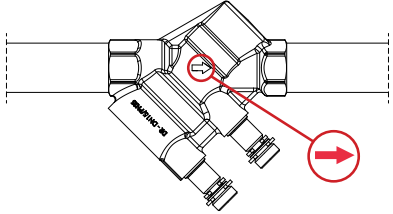
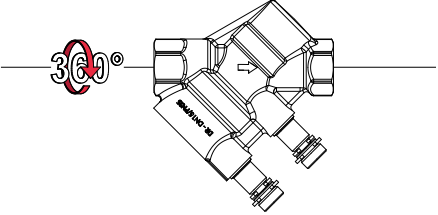
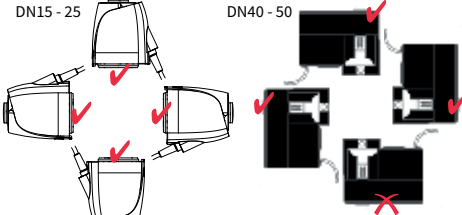
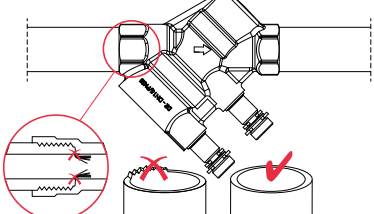
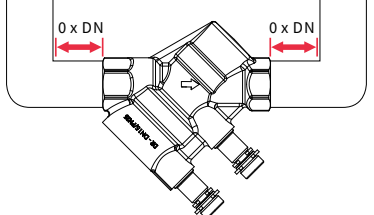
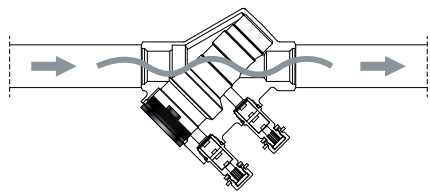
	<p>The arrow on the NexusValve Vivax housing indicates the flow direction to be respected.</p>
	<p>If the valve is to be used as an automatic flow limiter, without an actuator, it can be orientated 360° around the pipe axis.</p>
	<p>Both the NexusValve Vivax valves DN 15 - 25 and the NexusValve thermoelectric actuator can be installed in any position required. In case of the NexusValve Vivax valves DN 32 - 50 with the electro-mechanical actuator any position is allowed except for the one with NexusValve actuator positioned underneath the NexusValve Vivax valve.</p>
	<p>The pipe ends must be deburred to prevent system debris collecting and obstructing the valve. Hemp sealant tape must not be used as strands can hang inside the pipe and obstruct the operation of the valve.</p>
	<p>The NexusValve Vivax can be mounted directly onto bends and flexible pipes, etc - no straight piping is required.</p>
	<p>System flushing should be carried out before the flow control device is installed in the NexusValve Vivax housing. To enable flushing the valve is sealed with the pre-setting cap, provided along with the valve. Maximum pressure during system flushing is 16 bar and the maximum temperature allowed is 25°C.</p>

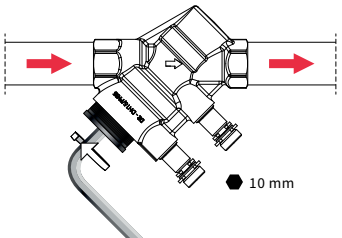
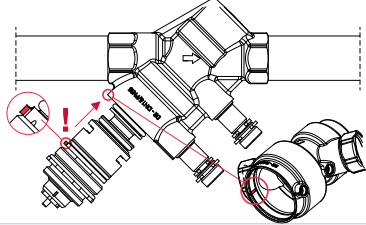
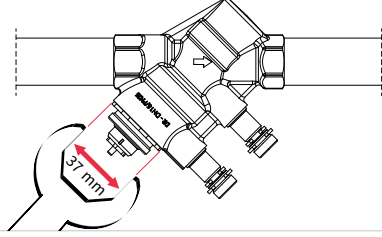
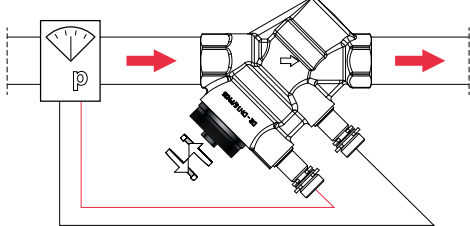
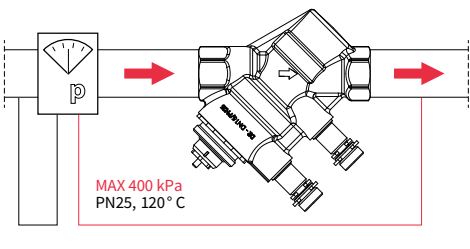
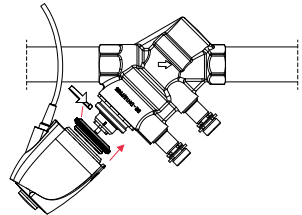
	<p>When the system flushing is completed, the pre-setting cap is removed from the valve housing using a 10 mm Allen key and the flow control device can be mounted.</p>
	<p>Note! The guide pin of the insert must correctly aligned with the groove before sliding the insert into the valve body.</p>
	<p>The flow control device is inserted and tightened carefully using a 37 mm key. No tool should be used on the small plastic nut on the top of the flow control device!</p>
	<p>A rough pre-setting of the flow is done using the presetting cap with a setting scale of 0-100% of the flow control device flow range. For a precise flow setting the NexusValve Balancing Computer is connected to the NexusValve Vivax. The pre-setting cap is then used to change the flow control device setting until the desired flow is displayed on the balancing computer.</p>
	<p>The maximum differential pressure permitted across the NexusValve Vivax is 400 kPa and the maximum permitted temperature is 120 °C.</p>
	<p>When using the NexusValve Vivax valve sizes DN 15 - 25 as a control valve, an appropriate and compatible actuator must be installed. An adapter is required on the valve housing before the Nexus-Valve actuation is clicked into place.</p>

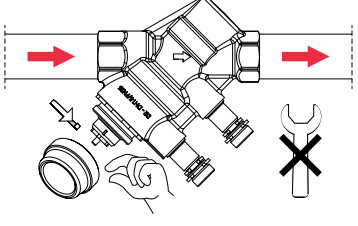
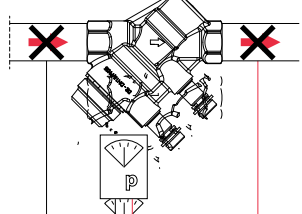
	<p>To isolate the system flow a NexusValve shut-off cap is mounted onto the NexusValve Vivax DN 15 - 32 valves. Since the valve offers leakage class IV some leakage shall be expected. The NexusValve shut-off cap may be tightened by hand only. Tools are not allowed for this purpose.</p>
	<p>Maximum differential pressure across the NexusValve Vivax valve must not exceed 400kPa neither during normal operation nor when the valve is in closed position.</p>

## 2. Introduction

### 2.7 Flow control accuracy

When set to a given flow, all valves based on the principle of dynamic balancing have a certain inaccuracy. Within the valve operating pressure range the real flow can deviate from the set design flow. In practise this means that the actual flow through the valve differs from what it was set to be because of pressure fluctuation in the system. This typically occurs from hysteresis and the desire to have a low starting pressure which is required for the differential pressure regulator in the valve to stabilize the flow. The starting pressure of the index valve contributes to the total system pressure loss and therefore influences the pump dimensioning.

The built-in differential pressure regulator stabilizes the flow across the NexusValve Vivax when the pressure loss across the valve is within 30 kPa to 400 kPa. When the pressure loss decreases below 30 kPa, the NexusValve Vivax operates with lower accuracy and at much lower differential pressure it enters into a static balancing zone.

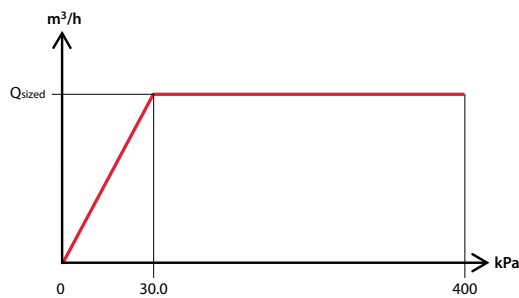

*The regulator ensuring constant differential pressure across the flow pre-setting unit and the two-way valve unit requires a pressure loss of minimum 30 kPa and maximum 400 kPa across the complete valve to operate properly. Within this pressure loss range the valve will maintain a constant flow (Q<sub>SIZED</sub>).*

The required starting differential pressure of 30 kPa across the NexusValve Vivax ensures a high flow control accuracy of at least  $\pm 7\%$ . The differential pressure working range is defined in the below graph: from P<sub>minA</sub> to P<sub>max</sub>. The flow tolerance, the same as the deviation from the Q<sub>sized</sub>, is within Q<sub>A</sub> - Q<sub>B</sub> ( $\pm 7\%$ ).

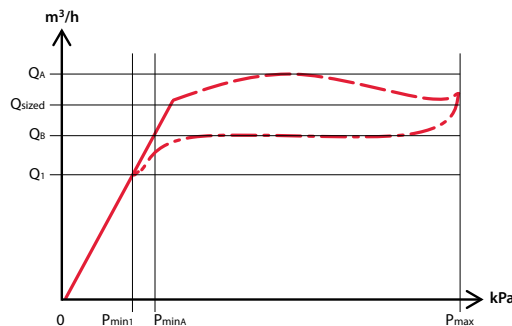

*The NexusValve Vivax minimum operating differential pressure in reference to the flow control accuracy.*

Common for pressure independent control valves is that a decrease in the differential pressure affects the accuracy of the valve.

The starting differential pressure specified for the NexusValve Vivax has for the above reason been carefully selected as 30 kPa. Decreasing this value from  $P_{minA}$  to  $P_{min1}$  would result in a desirable lower pump head, but the flow control accuracy would deteriorate accordingly:  $Q_A - Q_B < Q_A - Q_1$ . The high flow control accuracy will therefore achieve a better system energy efficiency compared to a pressure independent flow control valve with a low starting differential pressure.

## 2.8 Energy efficiency example

The below flow graph for the NexusValve Vivax DN 15L indicates that the accuracy in the high flow end is within  $\pm 5.8\%$  at a starting differential pressure of 30 kPa.

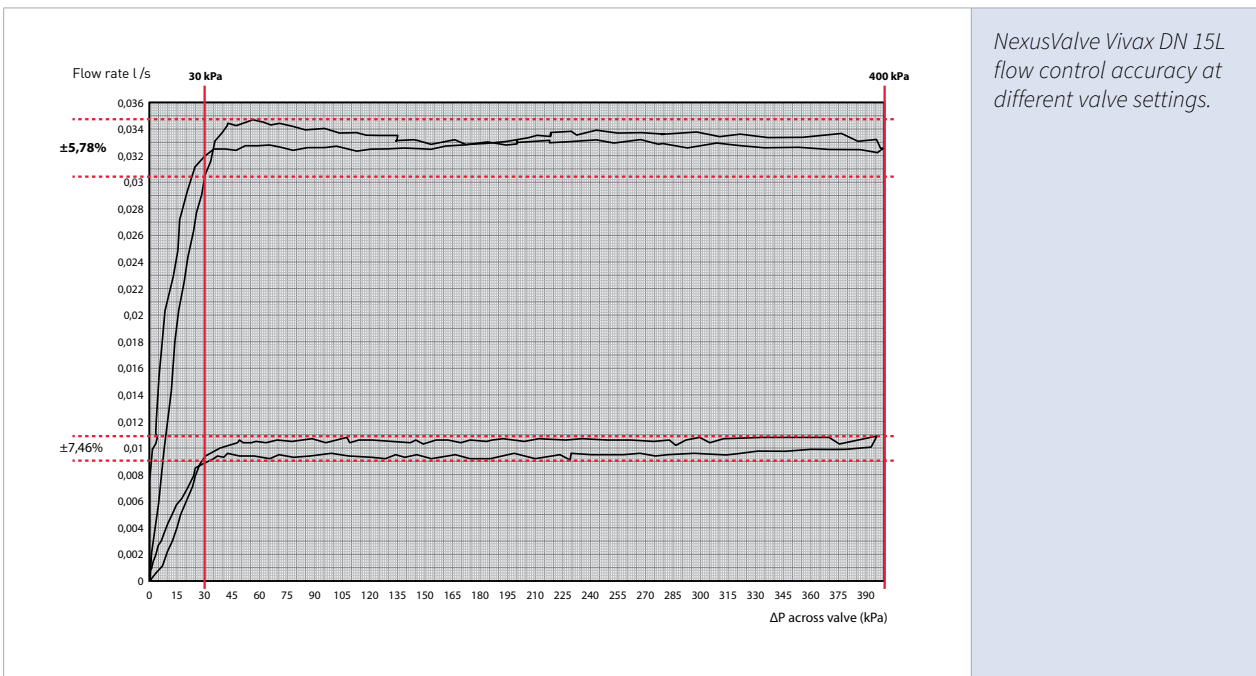

In this example a NexusValve Vivax DN 15L valve is installed in a heating system consisting of 35 terminal units. The supply and return water temperature difference is 20°C, the total required flow is 4.0 m<sup>3</sup>/h and the required pump head is 40 kPa, of which 30 kPa is required for the NexusValve Vivax DN 15L valve. The total system capacity is 93.3 kW and the pump requires 90 W power supply.

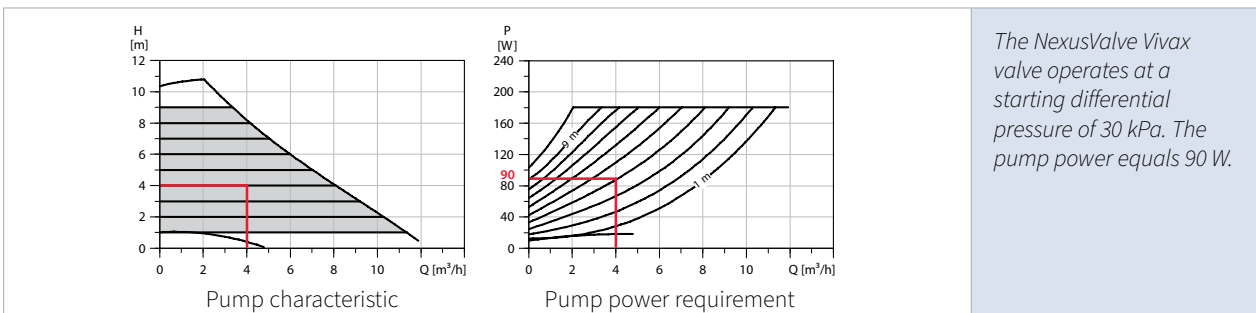

## 2. Introduction

If the initial differential pressure is reduced by 10 kPa to 20 kPa, the accuracy of the flow regulation simultaneously drops to approx.  $\pm 11\%$ .

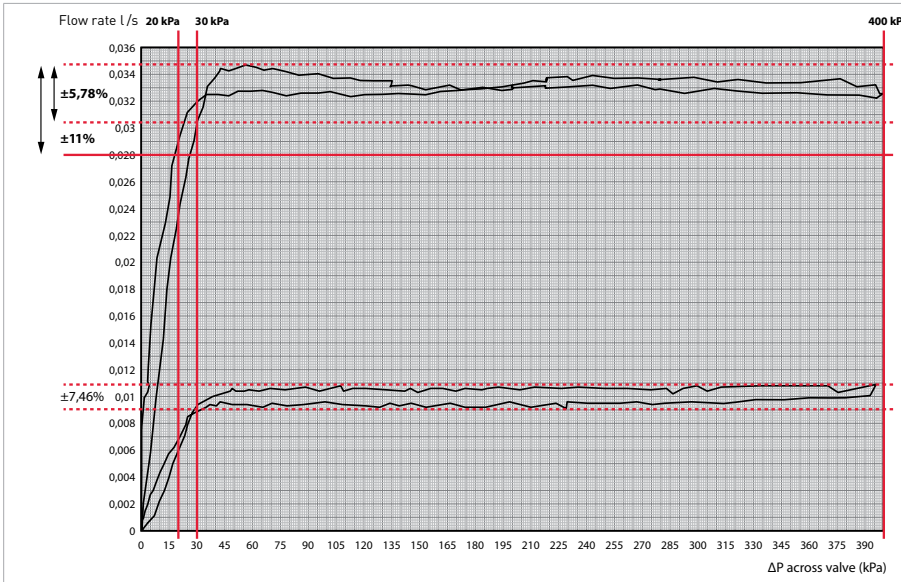

*The accuracy of the flow regulation of the NexusValve Vivax DN 15L at an initial differential pressure of 20 kPa.*

This reduced accuracy of the flow regulation can cause the total flow in the system to increase by  $11.0\% - 5.8\% = 5.2\%$ , which corresponds to an approx.  $0.2 \text{ m}^3/\text{h}$  greater flow and  $4.7 \text{ kW}$  greater energy consumption. The result is that the maximum excess supply in this example can lead to much higher energy consumption than if a pump more powerful by 10 kPa were used.

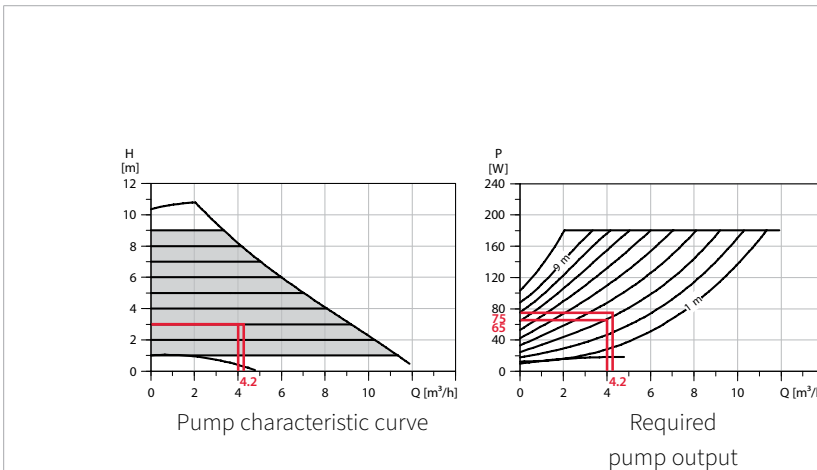

*A pressure-independent flow control valve at an initial differential pressure of 20 kPa. The difference in the flow regulation increases by  $\pm 5\%$ , while the pump output reduces to 75 W. The flow increases from  $4.0 \text{ m}^3/\text{h}$  ( $93.3 \text{ kW}$ ) at a pump output of 65 W to  $4.2 \text{ m}^3/\text{h}$  ( $98.0 \text{ kW}$ ) at a pump output of 75 W, which leads to an increase of  $4.7 \text{ kW}$  in the energy consumption in the regulated system.*

In this example, the energy savings created by using a less powerful pump are  $90 \text{ W} - 75 \text{ W} = 15 \text{ W}$ . When compared to the loss in accuracy caused by the potential excess supply, the energy savings in the pump are negligible. This shows that simply reducing the pump output by lowering the initial differential pressure is not a key factor and cannot be a stand-alone argument for greater energy efficiency.



The basic idea behind the development of the NexusValve Vivax was to be able to offer a high degree of accuracy with regard to flow regulation in order to achieve greater energy efficiency. This is the reason why the entire NexusValve Vivax range has been designed for an initial differential pressure of 30 kPa instead of only 20 kPa, which would impair the valve output. The high degree of accuracy of the flow regulation compensates for the higher differential pressure. This prevents excess supply and improves the energy efficiency of the system.

## 2.9 Actuators

There are different types of actuators for the NexusValve Vivax valves: Thermoelectric open / close 230/24 V and modulating 0-10V actuators for valve sizes DN 15-25; electromechanically modulating 24 V and 24/230 V three-point actuators for valve sizes DN 15-32; electromechanical open / close 230/24 V and modulating 0 - 10 V actuators for valve sizes DN 32-50. The diagram shows an example of the typical modulation properties of the NexusValve. The data is based on the properties of a NexusValve Vivax DN 15S. The diagram shows the flow rate at the various control voltages.

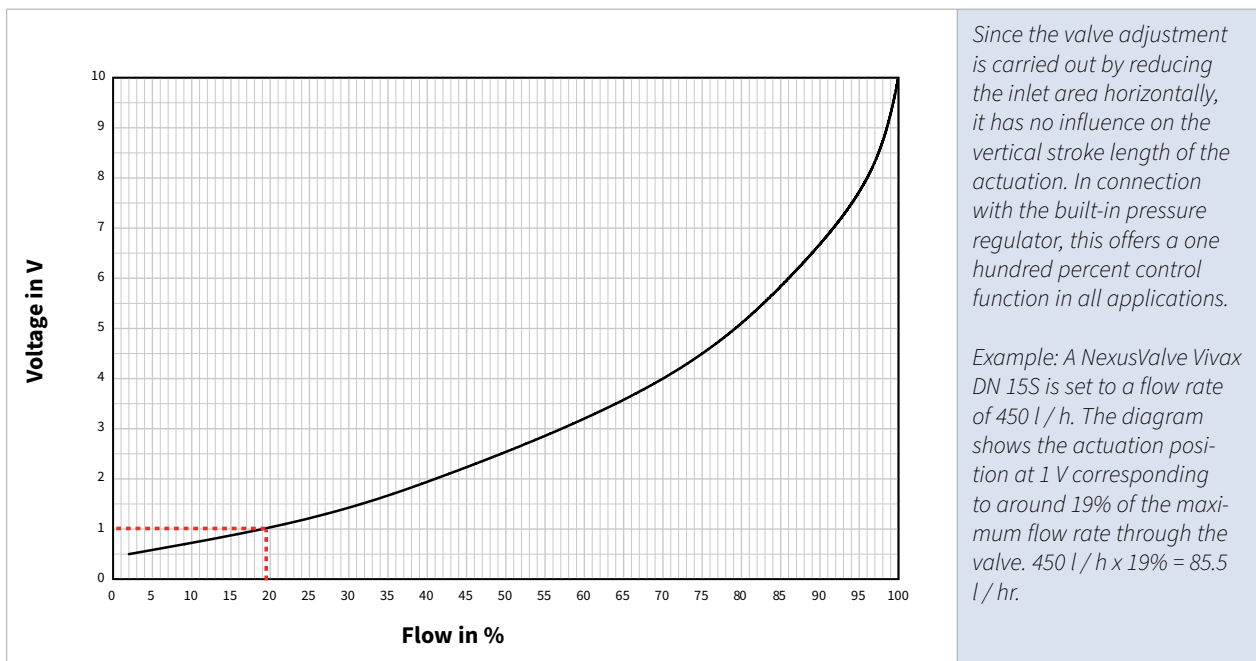

A thermostatic head with immersion sensor can also be used with the NexusValve Vivax. The set, comprising the valve, the thermostatic head and the sensor together with an immersion sleeve is called the NexusValve Vivax T.

## 2.10 NexusValve Vivax T

The NexusValve Vivax T is a combination of a pressure-independent flow rate limiter and a temperature limiter. The valve is supplied as part of a set with a thermostatic head, a temperature immersion sensor with immersion sleeve or a contact sensor. The thermostatic head can be assembled on the NexusValve Vivax DN 15-25. The valve closes when the water temperature on the immersion sensor corresponds to the temperature set on the thermostatic head.

The NexusValve Vivax T has been designed in particular for limiting the temperature of the water in the return line of mono-tube heating systems. Other applications in which temperature limitation of the return line water is required, e.g. increasing the heat efficiency, are also possible with the NexusValve Vivax T.

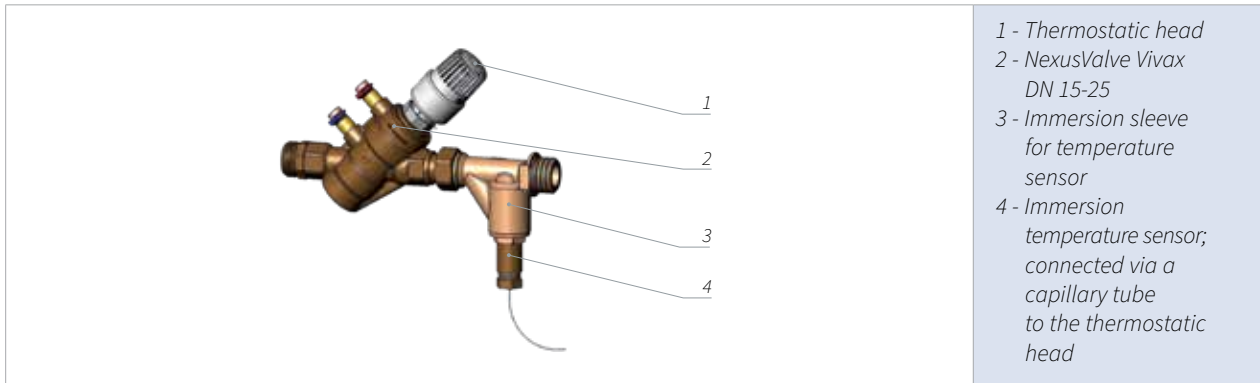

### Disabling the temperature adjustment range (on the Rotherm 2 thermostatic head)

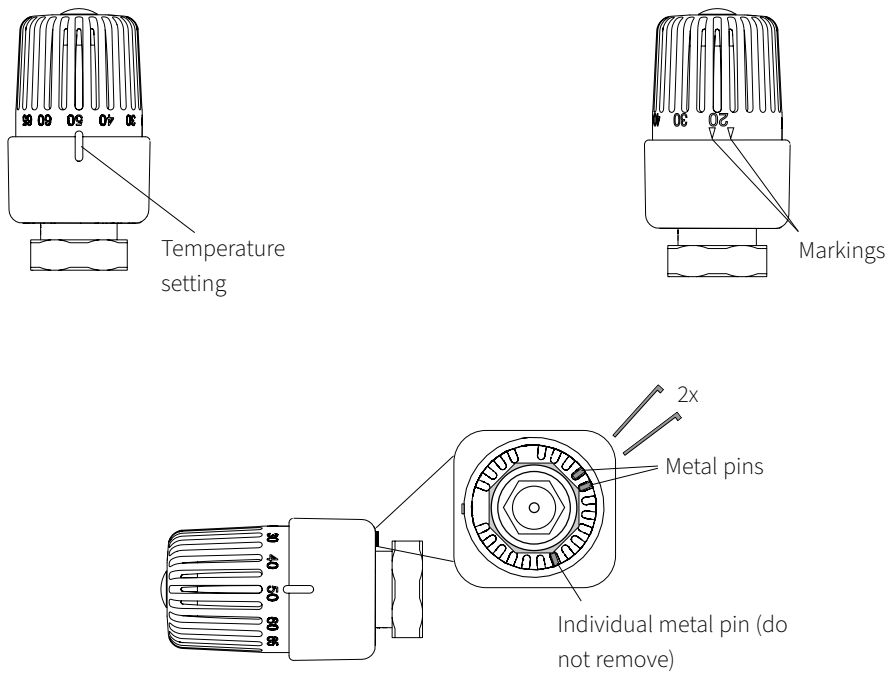

**Example: Locking the thermostatic valve at 40**

1

Remove the thermostatic head from the valve (body).

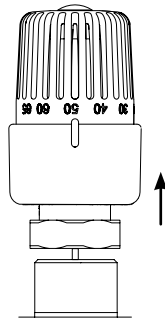

2

Remove the two metal pins with a screwdriver.

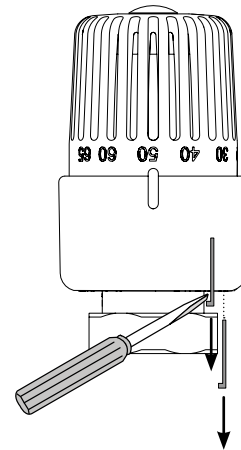

3

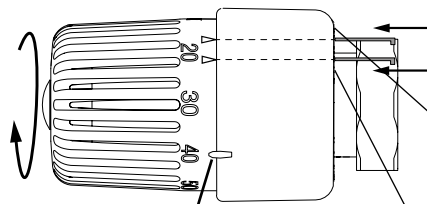

Select the temperature by rotating the head until it reaches 40.

To lock the thermostatic head, push the metal pins back in at the markings (see Fig. 3).

Note: there must be a gap between the two metal pins.

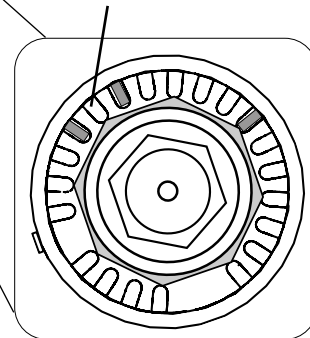

## 2. Introduction

### 2.11 Flushing the system

It is recommended that the system is flushed through once the NexusValve Vivax valves have been installed. To do so, remove the NexusValve Vivax valve insert and replace it with a red pre-adjustment cap, which will seal the valve during the flushing process. It is also recommended that sieves are installed in the system to protect terminal units and valves.



Once the system has been flushed, clean all filters and sieves. Remove the pre-adjustment cap and replace the valve insert in the valve housing and tighten it carefully.

### 2.12 Shut-off damper

The NexusValve Vivax DN 15-32 can be supplied with a shut-off damper, which shuts off the flow through the valve when it is installed in a system and is in operation. The shut-off damper is installed on the NexusValve Vivax valve in place of the actuator. Tightening the shut-off damper by hand ensures that the flow is shut off. Ensure that the differential pressure in both an open and a closed NexusValve Vivax valve never exceeds 400 kPa. The leakage class of the valve does not guarantee 100% leak tightness, which is why it is not recommended for use as a service valve.



## 2.13 Operation

No balancing is required if NexusValve Vivax valves are used. The valves are simply set to the required flow rate and compensate for pressure fluctuations in the system. This guarantees the hydraulic balancing within the system. If all of the valves are set to the required flow rate, the pump output is reduced to a minimum in order to prevent unnecessary energy consumption. The performance of the pump is optimised so that it only supplies enough pressure as the index valve requires for correct operation.

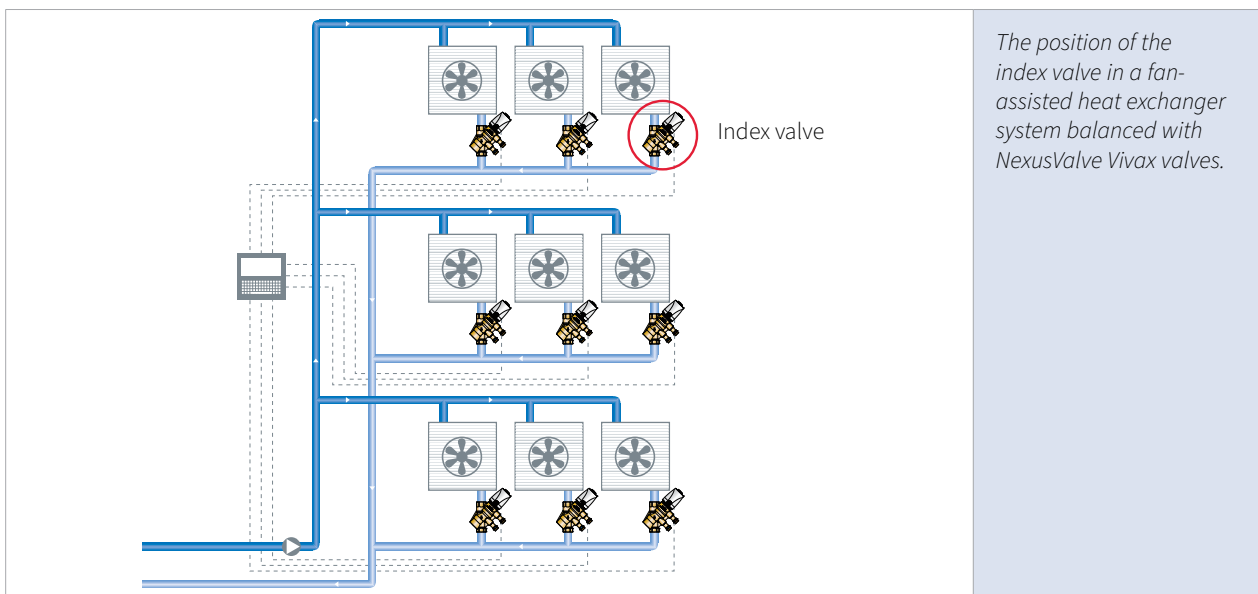

*The position of the index valve in a fan-assisted heat exchanger system balanced with NexusValve Vivax valves.*

The optimal pump setting is easy to find in a system with NexusValve Vivax valves. The pump is set to its maximum output during the pre-adjustment of the NexusValve Vivax valves. Once the valves have been pre-adjusted, a flow meter is connected to the index valve, i.e. to the valve for which the lowest differential pressure is available in the system. This is usually the valve located furthest from the pump.

The pump is then throttled down until the flow on the index valve starts to sink drastically. This is the point where the required minimum pressure has been reached. In order to ensure that sufficient pressure is available, the pump is gently throttled up again until the required flow rate of the index valve is displayed again in the flow meter. Hydraulic balancing is now complete, while the pump output is kept low.

## 2. Introduction

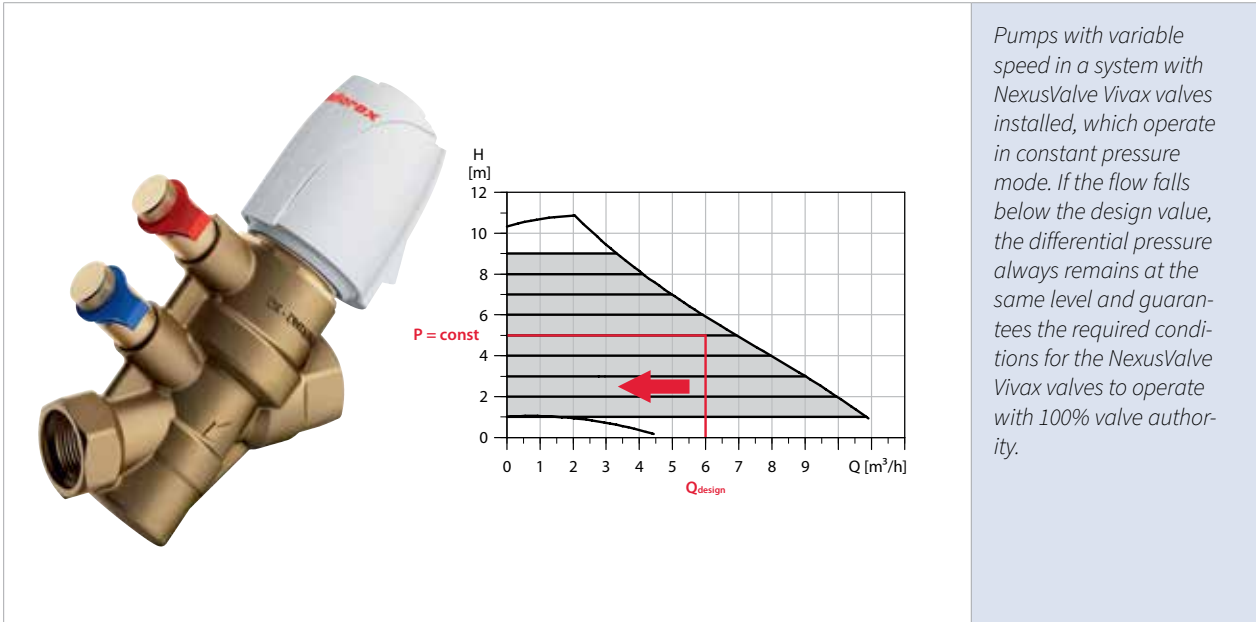

*Pumps with variable speed in a system with NexusValve Vivax valves installed, which operate in constant pressure mode. If the flow falls below the design value, the differential pressure always remains at the same level and guarantees the required conditions for the NexusValve Vivax valves to operate with 100% valve authority.*

When using a pump with variable speed, it is recommended operating it in an operating mode with a constant differential pressure. This ensures that the flow is set according to the actual load requirements and that the constant pressure ensures the required conditions so that the differential pressure regulator is able to function correctly in the NexusValve Vivax valves.

### 3. Applications

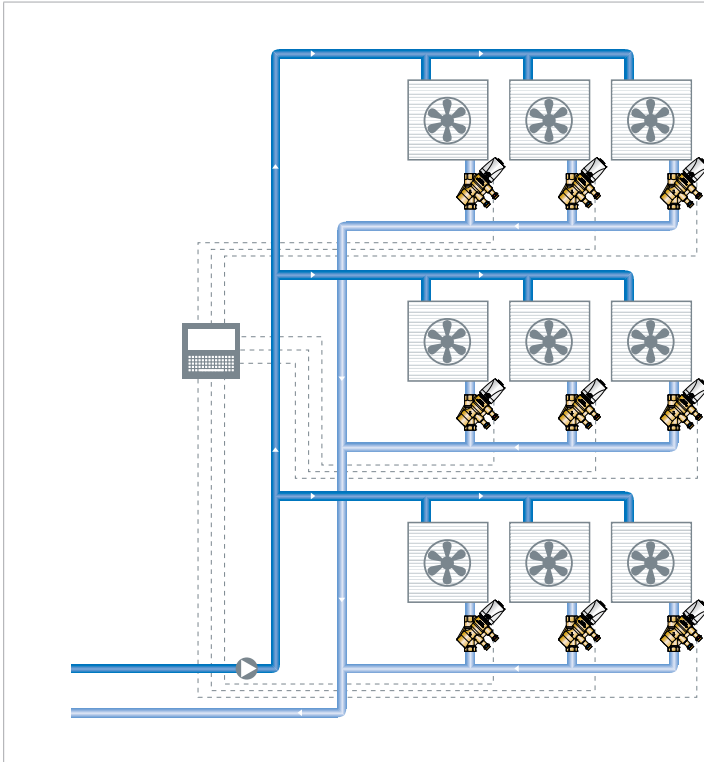

*Application 1 - Fan coil system with variable flow*

*The NexusValve Vivax will provide hydronic balance in variable flow systems and ensure sufficient flow at all load conditions in terminal units. The NexusValve actuator controlling the two-way valve inside the NexusValve Vivax is connected to a room thermostat or a BMS system. By opening or closing the two-way valve in reference to the room temperature, the NexusValve Vivax will ensure the required thermal indoor comfort.*

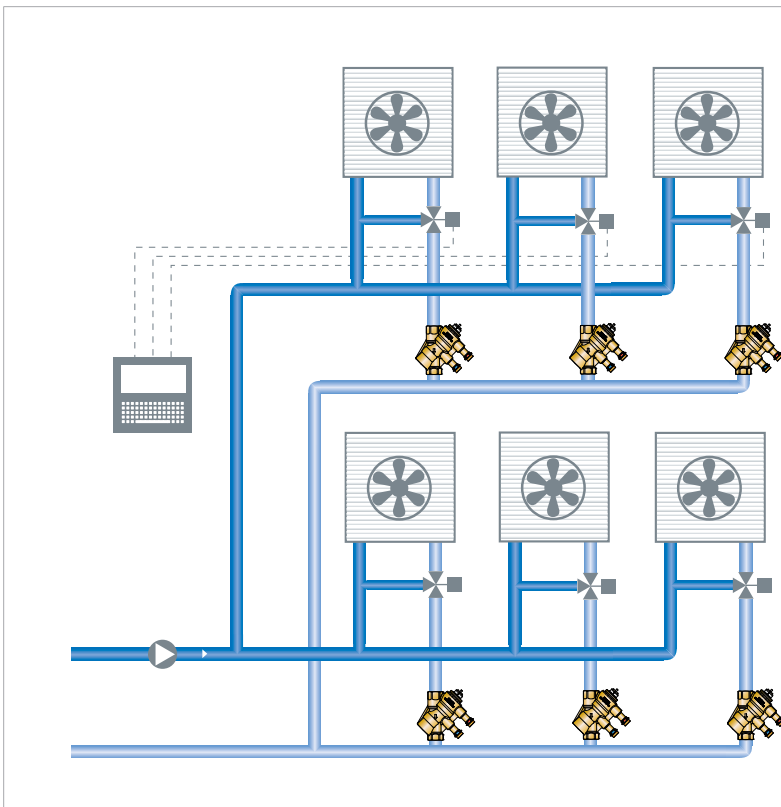

*Application 2 - Fan coil system with constant flow*

*The NexusValve Vivax will provide hydronic balance in a constant flow system equipped with three-way motorized valves and ensure sufficient flow at all load conditions in a fan coil or other terminal unit. The NexusValve Vivax is in this application without an actuator as the room temperature control is ensured by the operation of a three-way motorized valve. The three-way motorized valve is connected to a thermostat or a BMS system. By opening or closing the three-way valve in reference to the room temperature, the required thermal indoor comfort is achieved.*

### 3.Applications

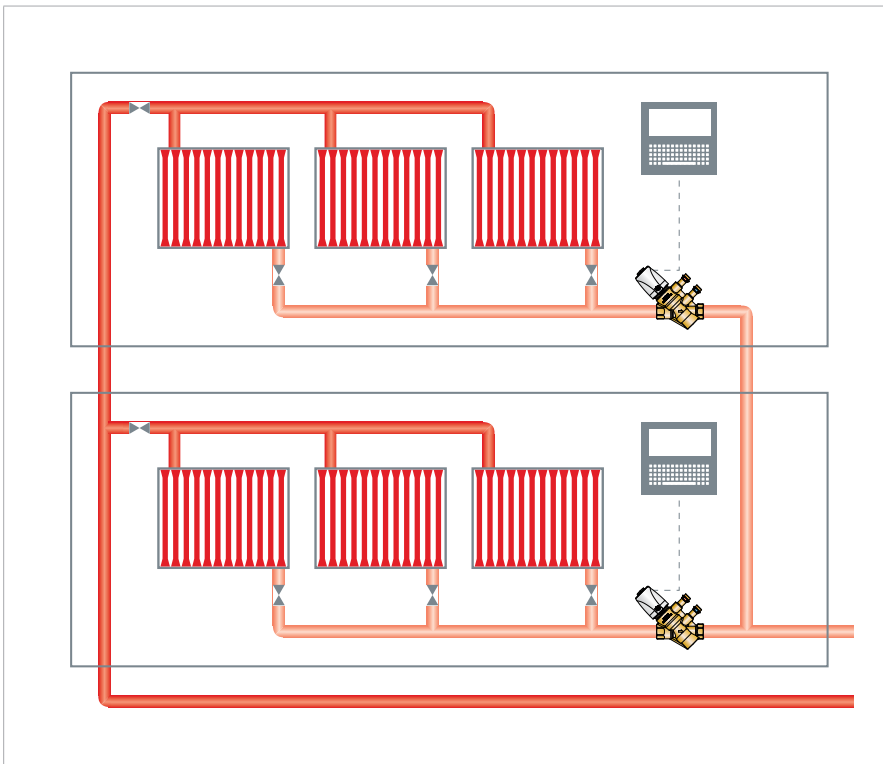

*Application 3 - Central heating system*

*The NexusValve Vivax can be installed in a branch of a central heating system with radiators or other terminal units. The NexusValve Vivax will in this way ensure that pressure fluctuations from the remaining part of the system will not affect the controlled branch, keeping the flow constant. The actuator controlling the two-way valve of NexusValve Vivax is connected to a thermostat or BMS system. By opening or closing the two-way valve in reference to the room temperature, the NexusValve Vivax will ensure the required thermal indoor comfort.*

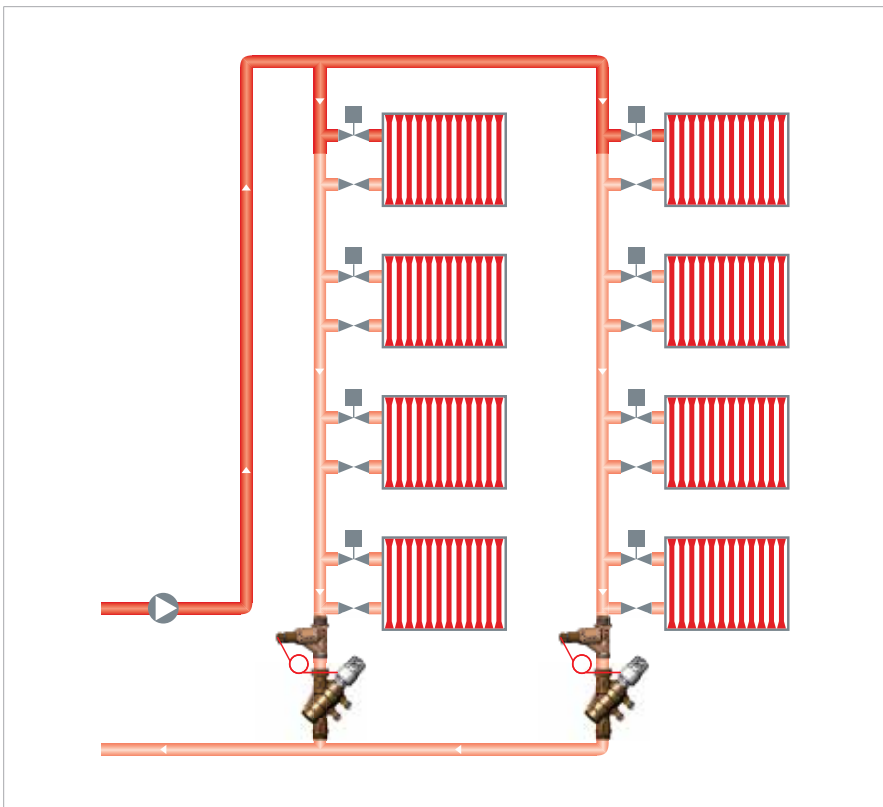

*Application 4 - One-pipe heating system*

*The NexusValve Vivax is in a one-pipe heating system installed with a thermostatic head and immersion temperature sensor. The NexusValve Vivax will operate as an automatic flow limiter ensuring the required water distribution in all the branches and risers. At the same time the thermostatic head will reduce water flow when the thermostatic radiator valves close.*



## 4. Product data sheet

### 4.1 Product finder

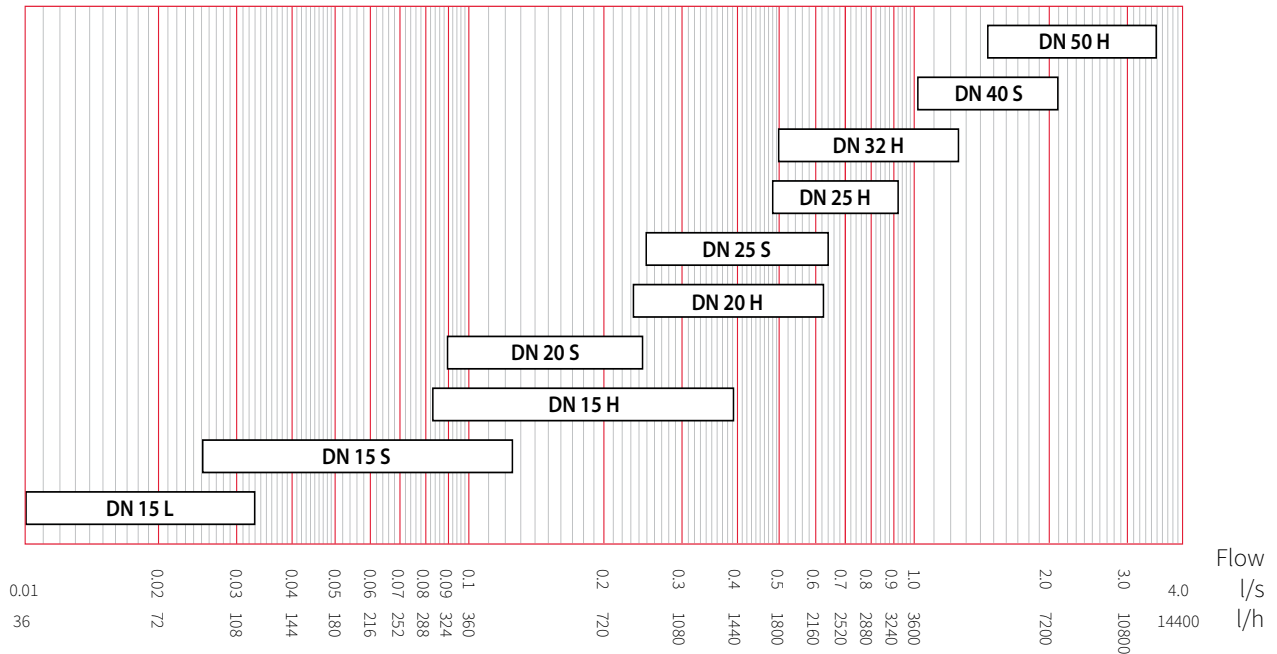

Flow range		Dimension	Colour code
l/s	l/h		
0.01-0.033	36-118	DN 15L	White
0.025-0.125	90-450	DN 15S	Red
0.083-0.39	300-1400	DN 15H	Black
0.089-0.245	320-882	DN 20S	White
0.232-0.617	835-2221	DN 20H	Black
0.240-0.650	865-2340	DN 25S	White
0.485-0.925	1750-3330	DN 25H	Black
0.530-1.220	1910-4400	DN 32H	Black
1.02-2.10	3670-7560	DN 40S	White
1.44-3.50	5180-12600	DN 50H	Black

## 4. Product data sheet

### 4.2 NexusValve Vivax DN 15-50

#### 4.2.1 DN 15-32 female/female

##### Dimensions

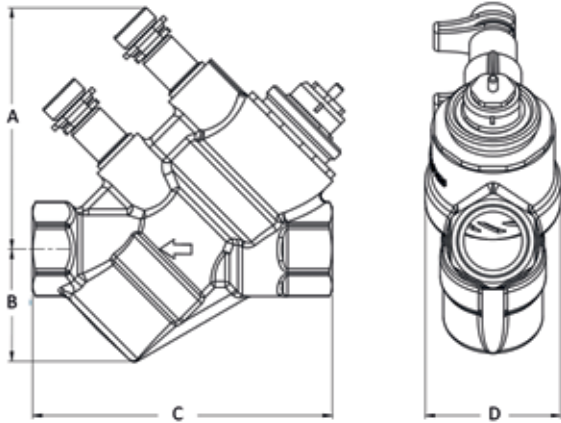

##### Specifications

<b>Max. temperature</b>	120°C
<b>Min. temperature</b>	-20°C
<b>Max. pressure</b>	PN25
<b>Operating pressure</b>	30-400 kPa
<b>Marking on valve</b>	DN, PN, flow direction, DR
<b>Connection</b>	Female thread ISO 7/1 parallel
<b>Valve housing</b>	DR Brass CW602N
<b>Flow control device</b>	PPS
<b>Sealings</b>	O-rings EPDM
<b>Diaphragm</b>	Reinforced EPDM

DN	A (mm)	B (mm)	C (mm)	D (mm)
DN 15L	76	35	95	44
DN 15S	76	35	95	44
DN 15H	76	35	95	44
DN 20S	83	49	120	55
DN 20H	83	49	120	55
DN 25S	81	56	127	71
DN 25H	81	56	127	71
DN 32H	87	72	154	82

**Note!** Information on insulation jackets, press adaptors and other is provided in the chapter Accessories.

Valve	Article	Dimension	Nom. Inch	Kvm m <sup>3</sup> /h	Flow range l/h
<b>DN 15</b> 	MN80597.001	DN 15L	½"	0.23	36-118
	MN80597.002	DN 15S	½"	0.78	90-450
	MN80597.003	DN 15H	½"	2.50	300-1400
<b>DN 20</b> 	MN80597.004	DN 20S	¾"	1.90	320-882
	MN80597.005	DN 20H	¾"	4.70	835-2220
<b>DN 25</b> 	MN80597.006	DN 25S	1"	5.05	865-2340
	MN80597.007	DN 25H	1"	8.25	1750-3330
<b>DN 32</b> 	MN80597.008	DN 32H	1¼"	8.35	1910-4400

**Note!** The Kvm value refers to the pressure loss across the measuring points and must only be used for flow verification during system commissioning.

## 4. Product data sheet

### 4.2.2 DN 40-50 female/female

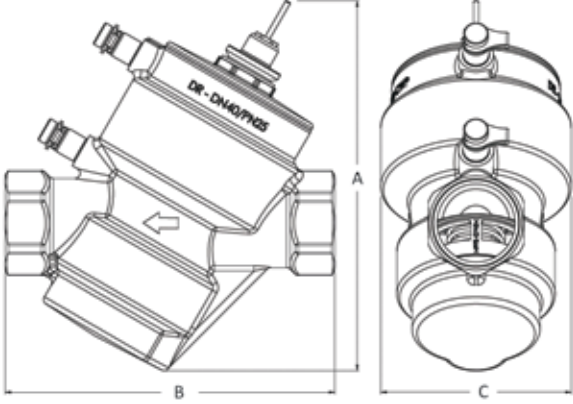
Dimensions	Specifications
	<p><b>Max. temperature</b> 120°C  <b>Min. temperature</b> -20°C  <b>Max. pressure</b> PN25  <b>Operating pressure</b> 30-400 kPa  <b>Marking on valve</b> DN, PN, flow direction, DR  <b>Connection</b> Female thread ISO 7/1 parallel  <b>Valve housing</b> DR Brass CW602N  <b>Flow control device</b> PPS  <b>Sealings</b> O-rings EPDM  <b>Diaphragm</b> Reinforced EPDM</p>

DN	A (mm)	B (mm)	C (mm)
DN 40S	212	189,5	ø 109,5
DN 50H	210	195	ø 110,5

**Note!** Information on insulation jackets, press adaptors and other is provided in the chapter Accessories.

Valve	Article	Dimension	Nom. Inch	Kvm m <sup>3</sup> /h	Flow range l/h
<b>DN 40</b> 	MN80597.010	DN 40S	1½"	17.5	3670-7560
<b>DN 50</b> 	MN80597.013	DN 50H	2"	29.5	5180-12600

**Note!** The Kvm value refers to the pressure loss across the measuring points and must only be used for flow verification during system commissioning.

### 4.2.3 NexusValve Vivax T DN 15-25 with temperature limiter / sensor

#### Dimensions

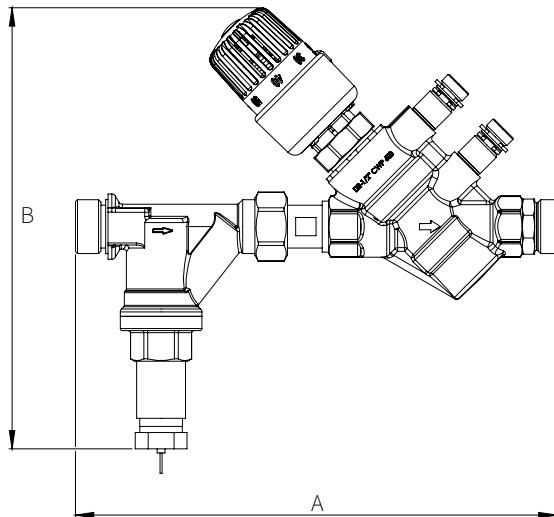

#### Specifications

##### Valve

<b>Max. temperature</b>	120°C
<b>Min. temperature</b>	-20°C
<b>Max. pressure</b>	PN25
<b>Operating pressure</b>	30-400 kPa
<b>Marking on valve</b>	DN, PN, flow direction, DR
<b>Connection</b>	Male thread ISO 7/1 parallel
<b>Valve housing</b>	DR Brass CW602N
<b>Flow control device</b>	PPS
<b>Sealings</b>	O-rings EPDM
<b>Diaphragm</b>	Reinforced EPDM

##### Thermostatic head

<b>Thermostatic head</b>	Rotherm 2
<b>Temperature setting range</b>	20-65°C



##### Temperature sensor

<b>Type</b>	Immersion
<b>Capillary length</b>	2.0m
<b>Housing</b>	CW617N
<b>Sealings</b>	EPDM
<b>Filter mesh</b>	Stainless steel 1.4301

DN	A (mm)	B (mm)
DN 15L	236	216
DN 15S	236	216
DN 15H	236	216
DN 20S	270	217
DN 20H	270	217
DN 25S	274	240
DN 25H	274	240

**Note!** Information on insulation jackets, press adaptors and other is provided in the chapter Accessories.

## 4. Product data sheet

Valve	Article	NexusValve Vivax	End connections	Kvm m <sup>3</sup> /h	Flow range l/h
<b>DN 15</b> 	MN80597.121	DN 15L	½"	0.23	36-118
	MN80597.122	DN 15S	½"	0.78	90-450
	MN80597.123	DN 15H	½"	2.50	300-1400
<b>DN 20</b> 	MN80597.124	DN 20S	¾"	1.90	320-882
	MN80597.125	DN 20H	¾"	4.70	835-2220
<b>DN 25</b> 	MN80597.126	DN 25S	1"	5.05	865-2340
	MN80597.127	DN 25H	1"	8.25	1750-3330

**Note!** The Kvm value refers to the pressure loss across the measuring points and must only be used for flow verification during system commissioning.

Valve	Article	NexusValve Vivax T with contact sensor
<b>DN 15 L</b>	MN80597.1210	DN 15L ½"
<b>DN 15 S</b>	MN80597.1220	DN 15S ½"
<b>DN 15 H</b>	MN80597.1230	DN 15H ½"
<b>DN 20 S</b>	MN80597.1240	DN 20S ¾"
<b>DN 20 H</b>	MN80597.1250	DN 20H ¾"
<b>DN 25 S</b>	MN80597.1260	DN 25S 1"
<b>DN 25 H</b>	MN80597.1270	DN 25H 1"

### 4.3 Flow diagrams

The black line in the graphs specifies the NexusValve Vivax setting at a given flow. This flow is kept constant at a differential pressure range between 30-400 kPa across the NexusValve Vivax.

#### DN 15L - female/female

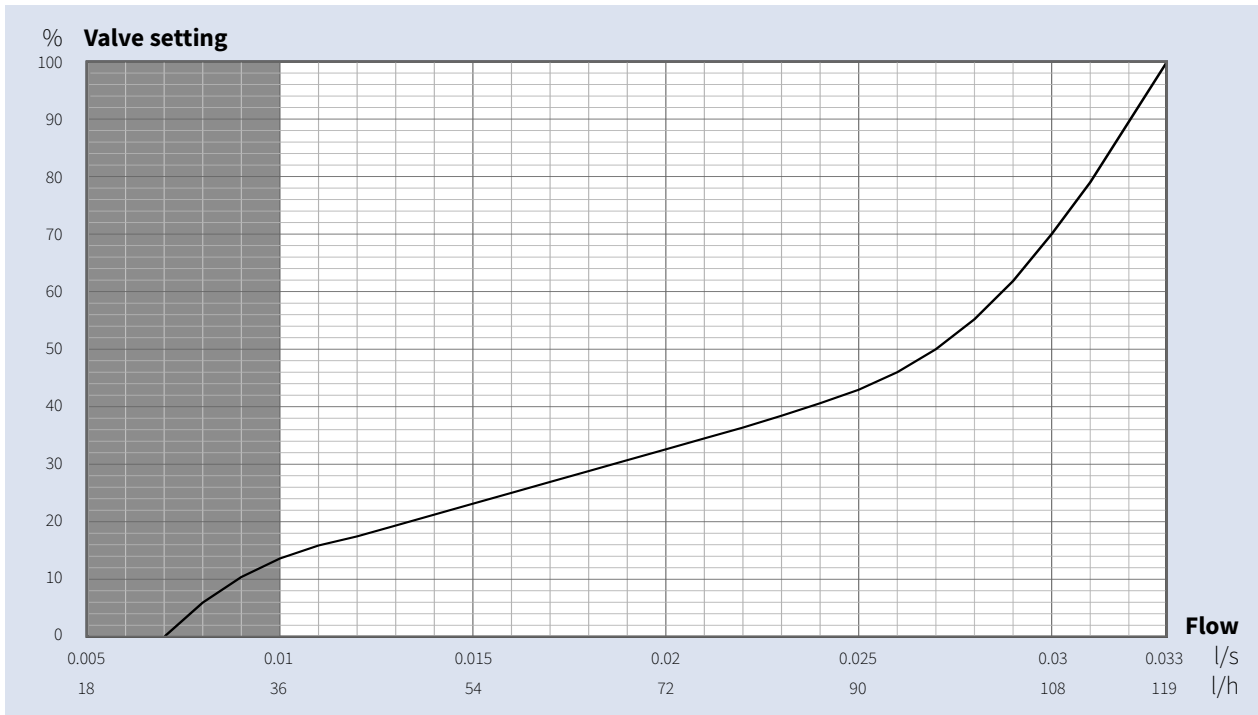

A high measuring accuracy is achieved across the entire setting range, but a setting below 14% is not recommended. At a setting below 14% the pressure loss across the Fluctus orifice will be below 3.0 kPa which is the minimum requirement for a  $\pm 3\%$  flow measuring tolerance accuracy.

# 4. Product data sheet

## DN 15S - female/female

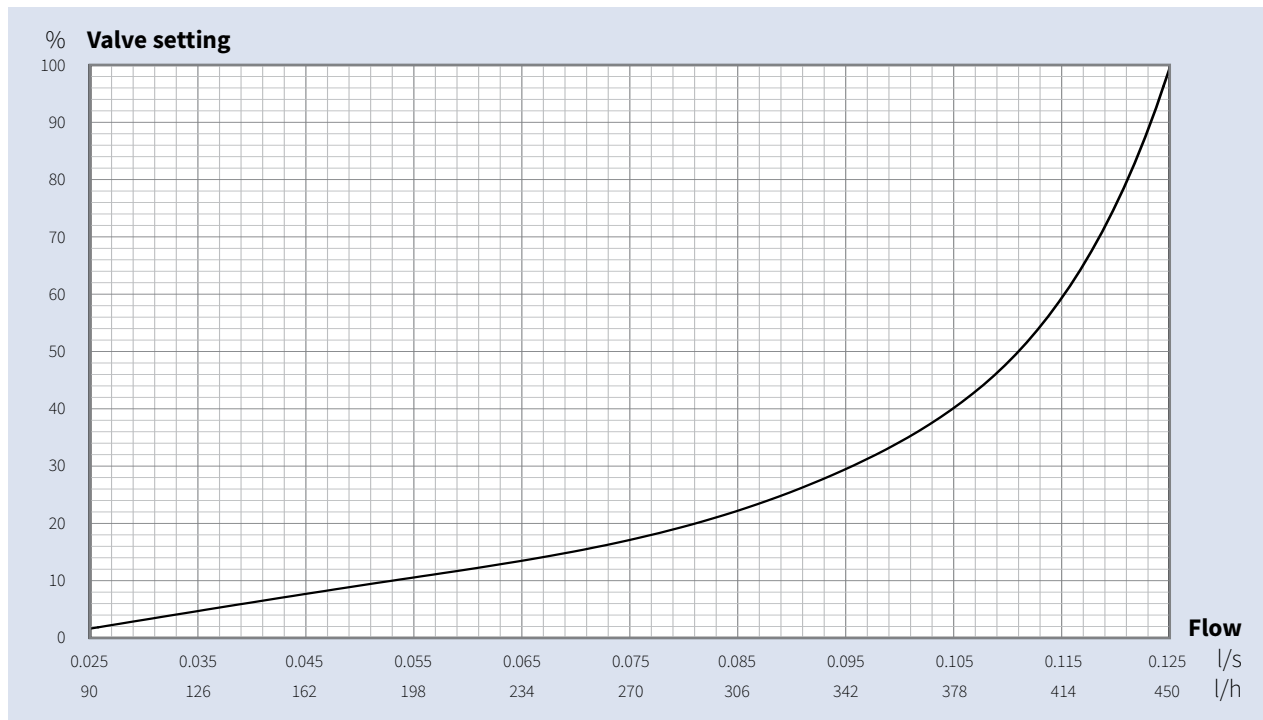



**DN 15H - female/female**

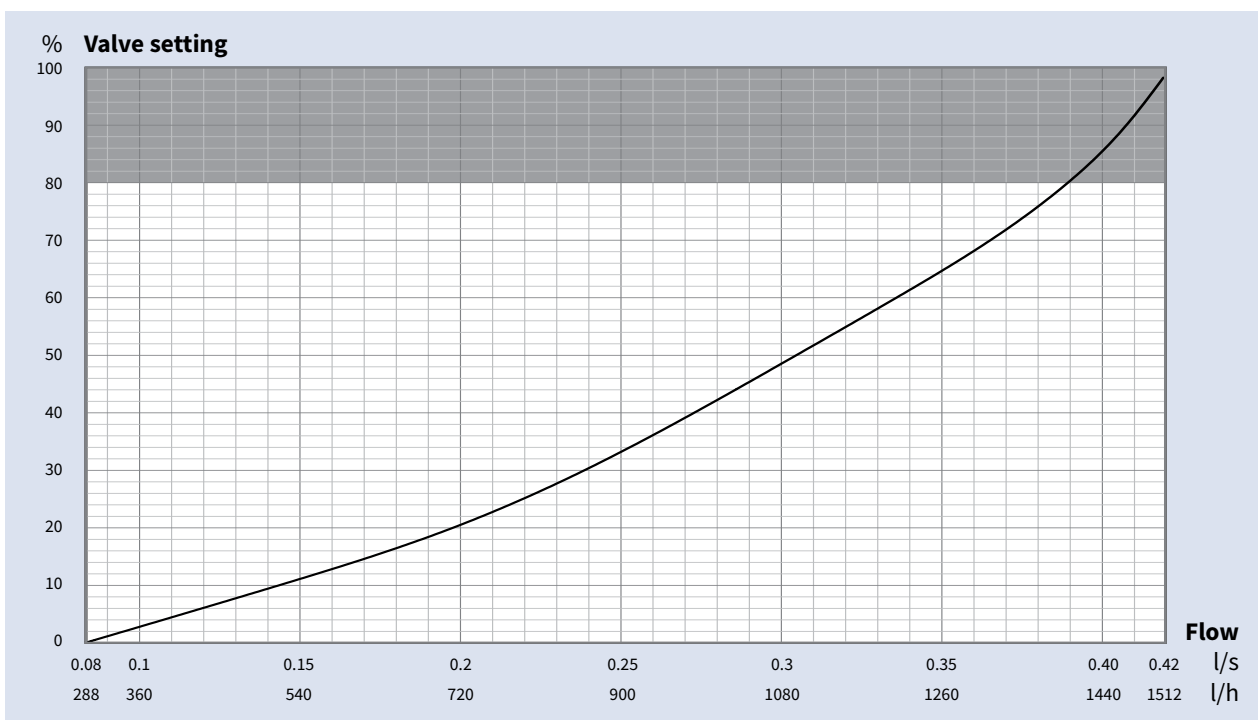

In order to provide high measuring accuracy the whole setting range with the exception of 80-100% is recommended. At a setting above 80% the specified flow will still be kept constant, but the flow reading accuracy of  $\pm 3\%$  cannot be guaranteed.

# 4. Product data sheet

## DN 20S - female/female

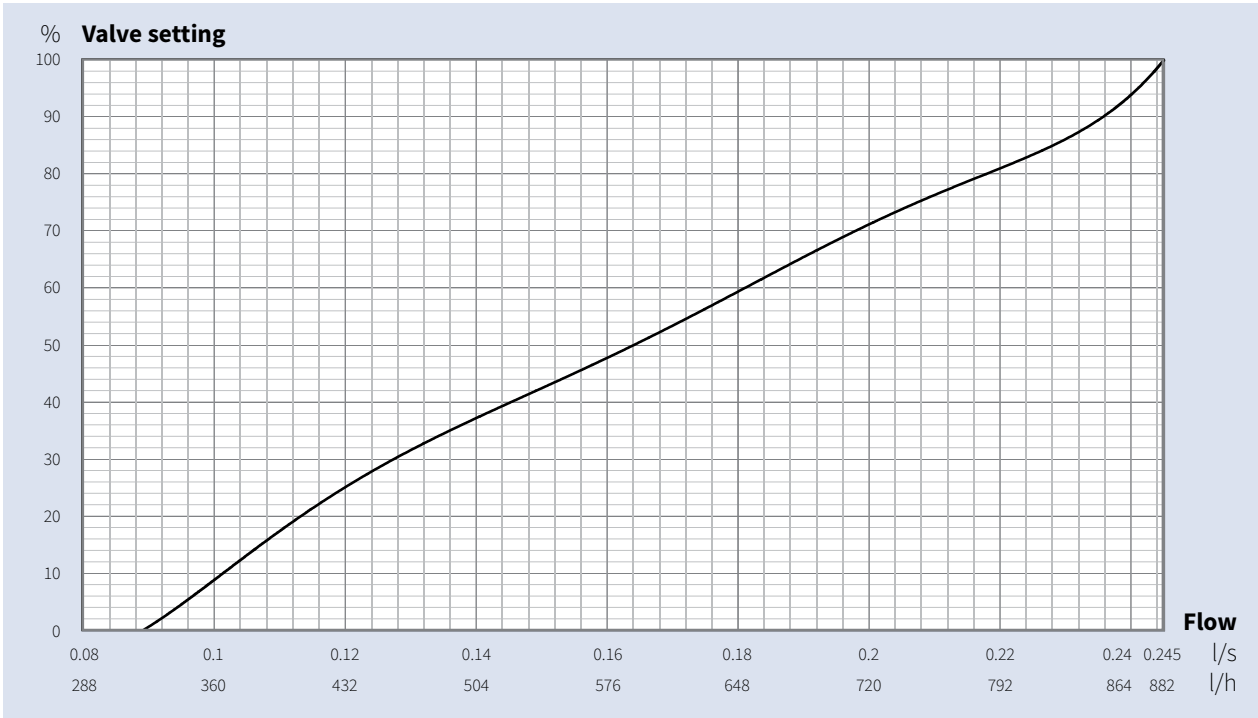

## DN 20H - female/female

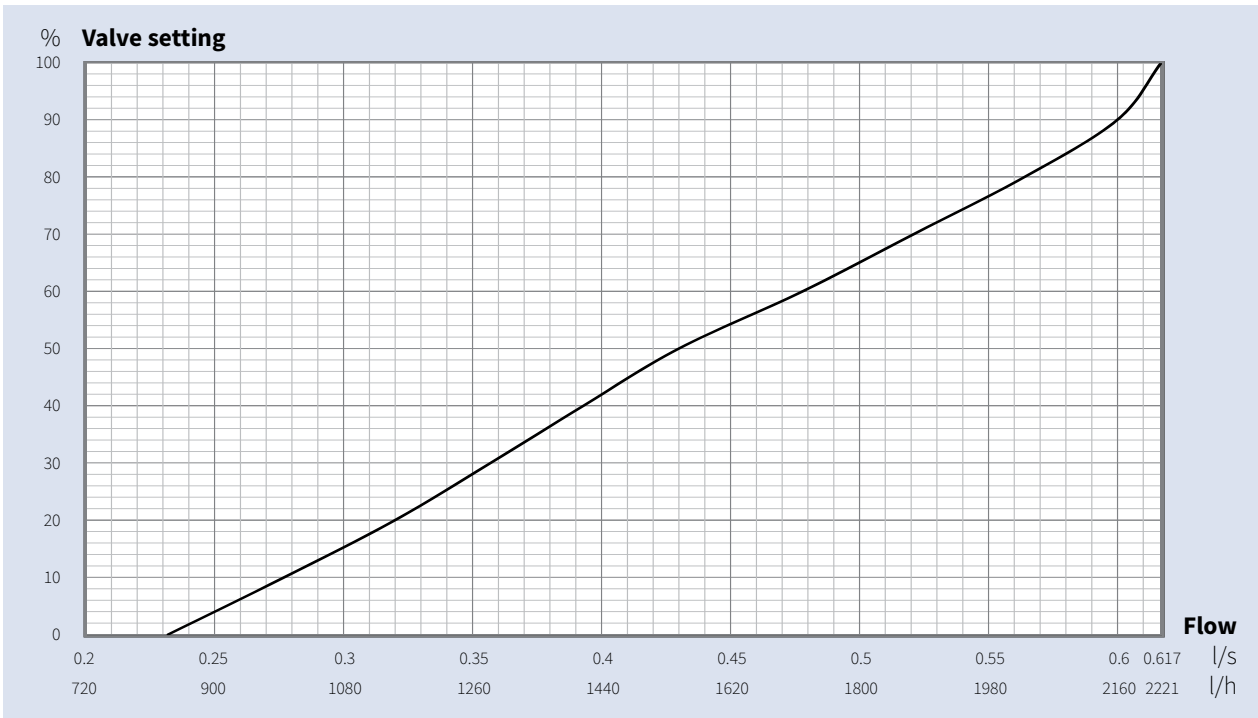

**DN 25S - female/female**

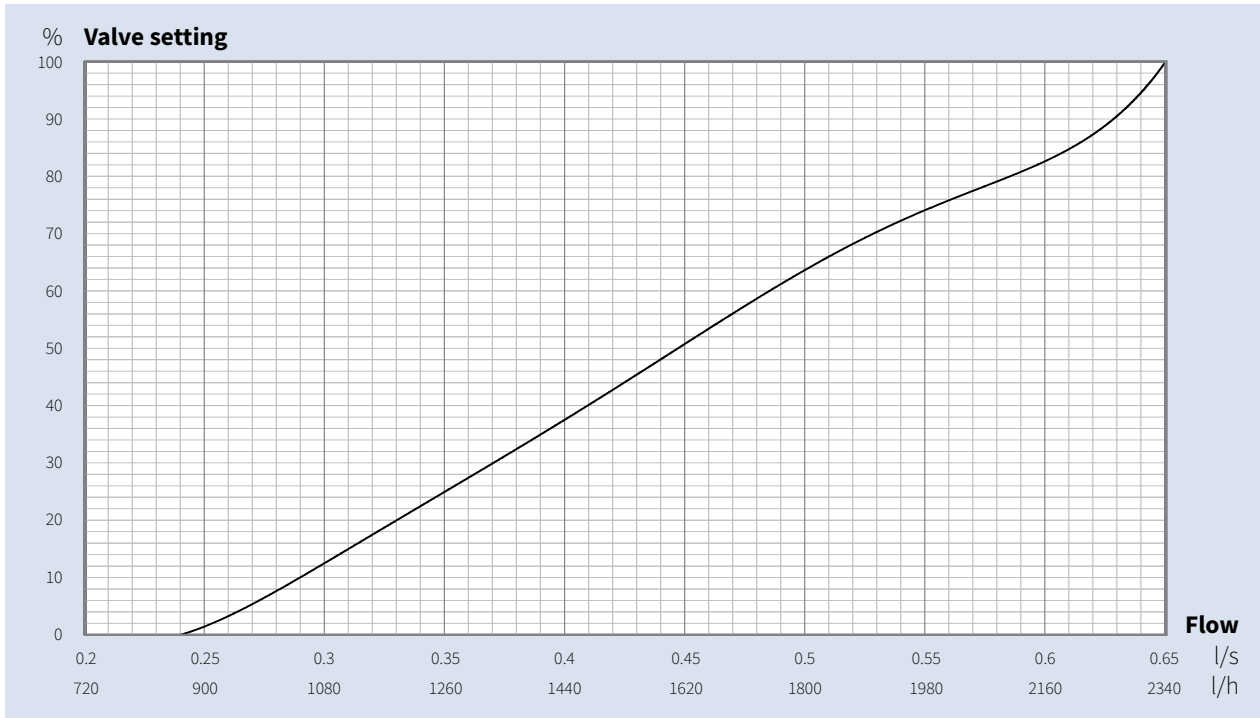

**DN 25H - female/female**

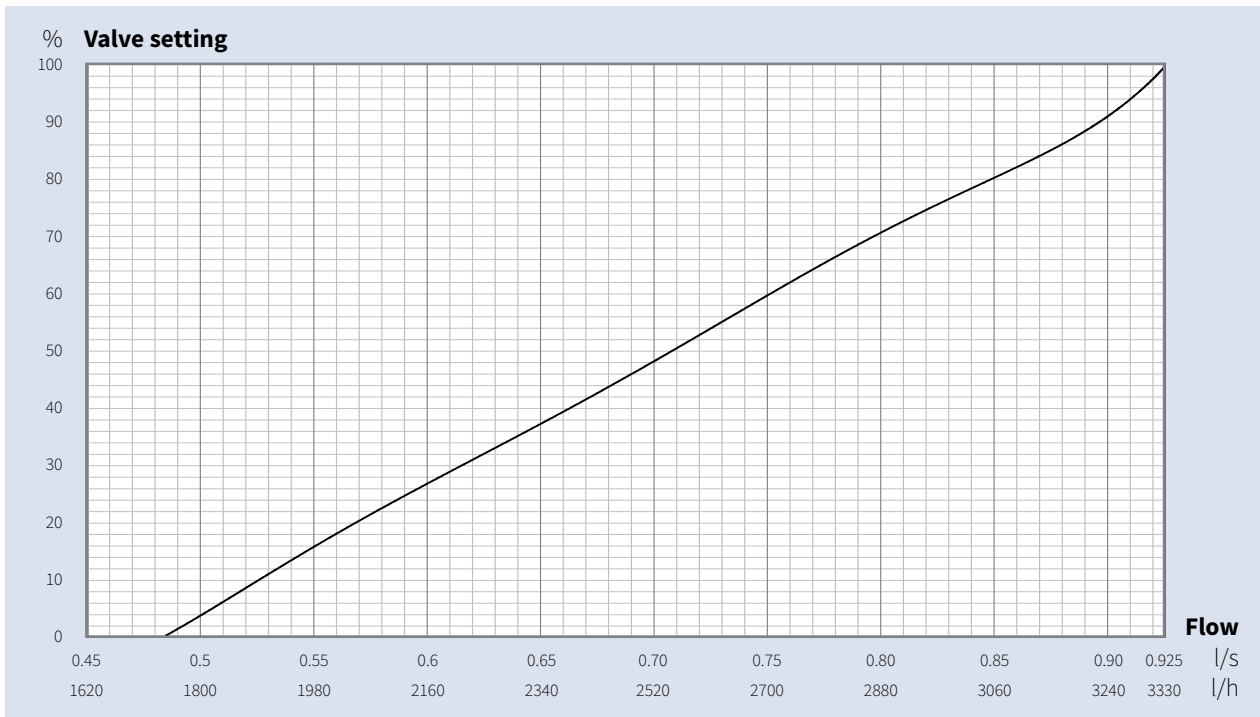

## 4. Product data sheet

### DN 32H - female/female

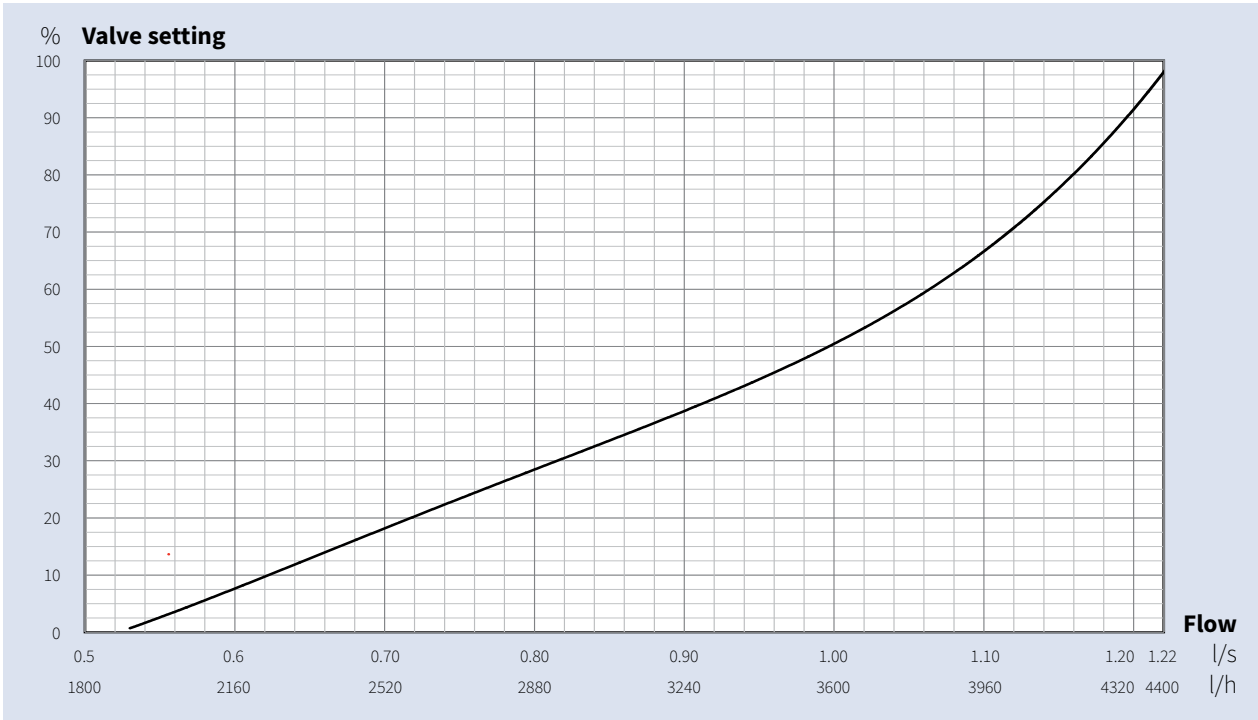

### DN 40S - female/female

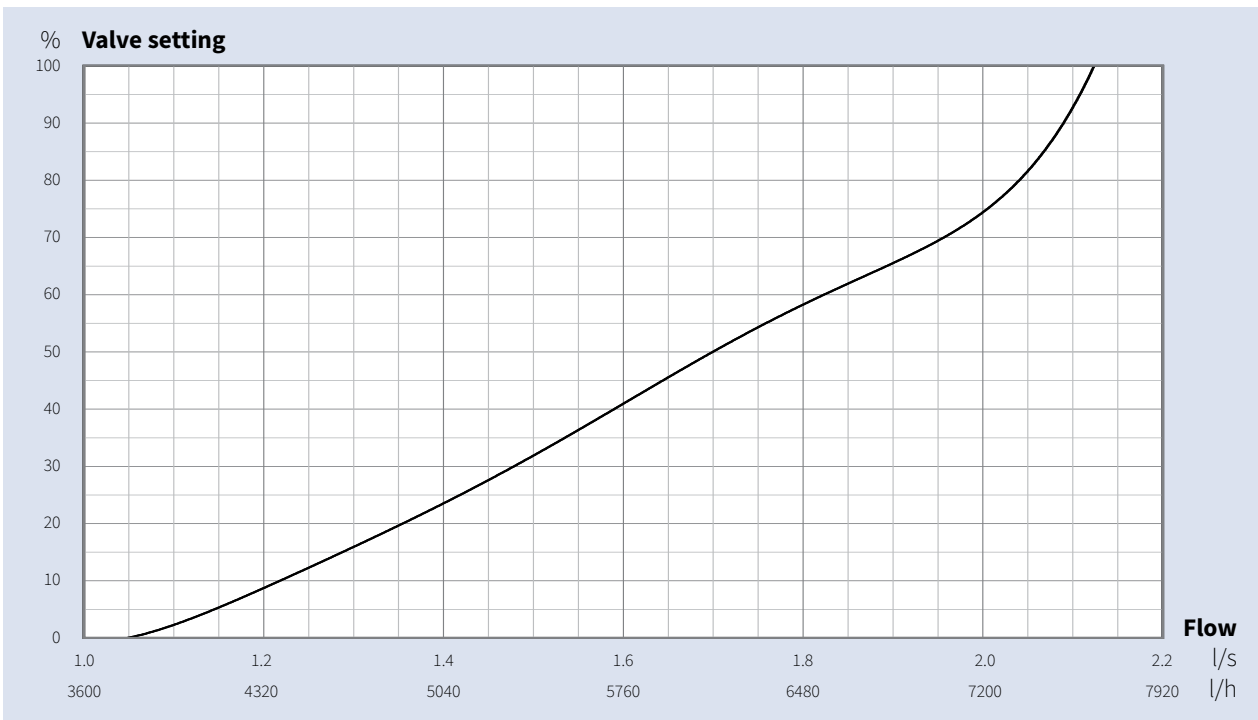

**DN 50H - female/female**

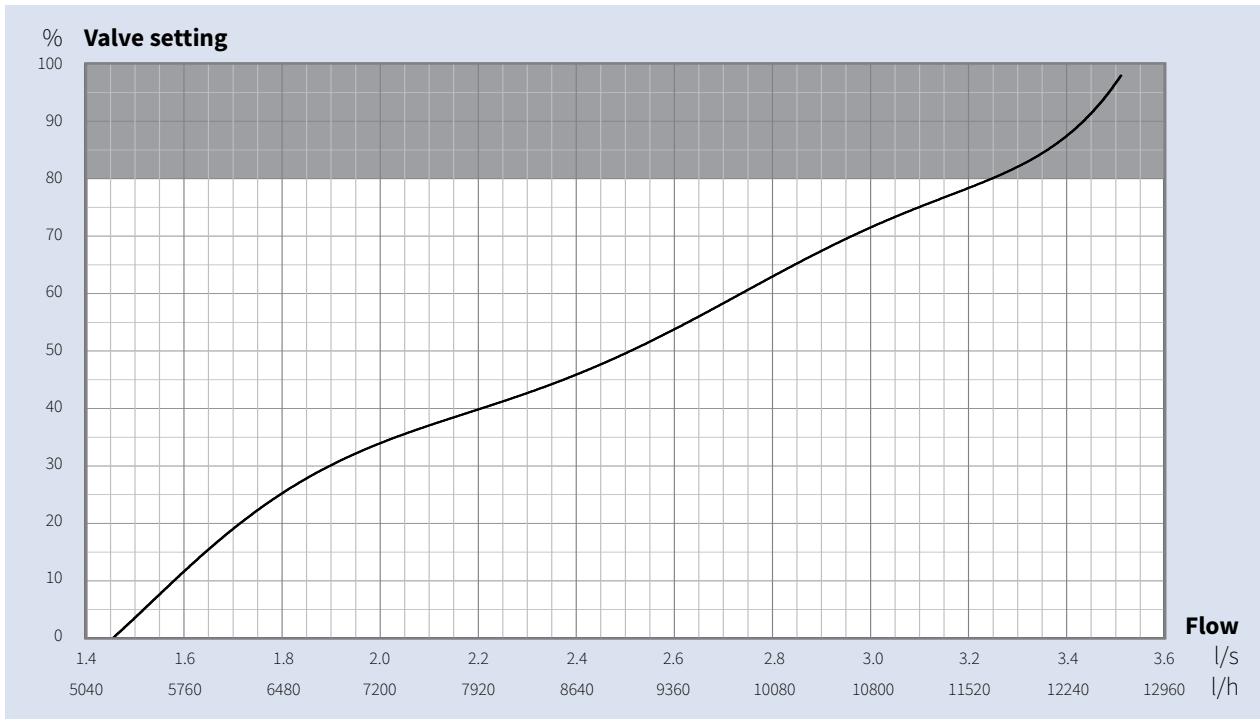

The high measuring accuracy of  $\pm 3\%$  is available within the setting range of 0-80%. In the setting range of 80-100% the measuring accuracy is  $\pm 8\%$ .

## 4. Product data sheet

### 4.4 Measuring signal diagrams

The red dotted line graphs represent the differential pressure – measuring signal – across the Fluctus orifice of a NexusValve Vivax valve at a given flow. These graphs are used during the system commissioning.

The fixed Kvm value of the built-in Fluctus nozzle in the NexusValve Vivax valve is used for direct flow verification. By connecting a flowmeter to the measuring points of the NexusValve Vivax and entering the Kvm value into the flowmeter, the actual flow through the NexusValve Vivax is shown on the flowmeter display. The pre-setting tool is then rotated until the required flow is reached.

#### DN 15L - female/female

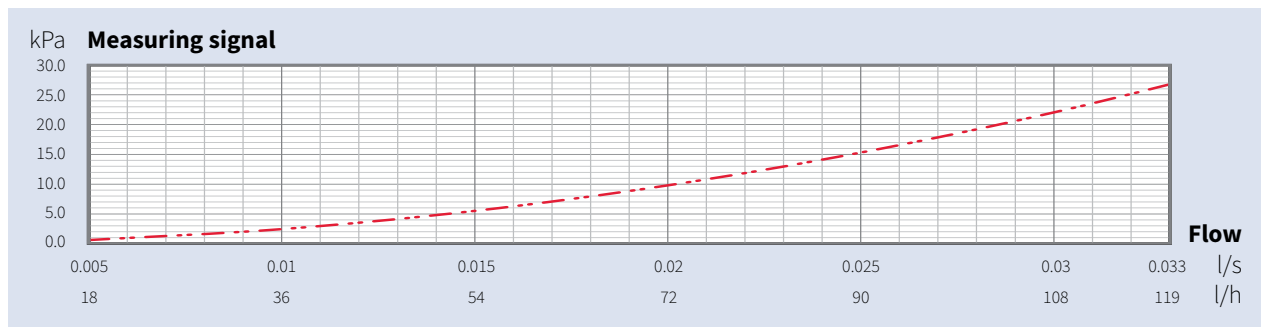

#### DN 15S - female/female

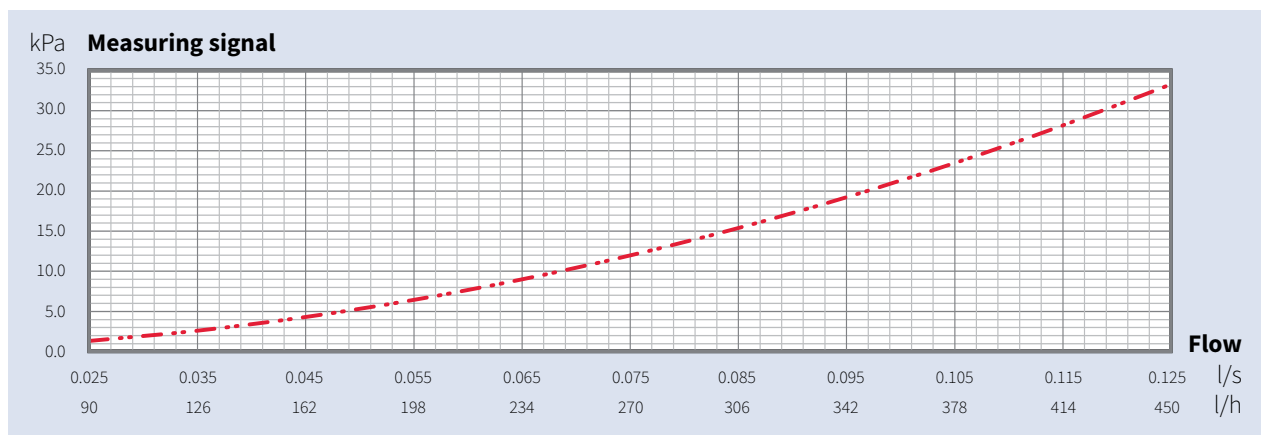

**DN 15H - female/female**

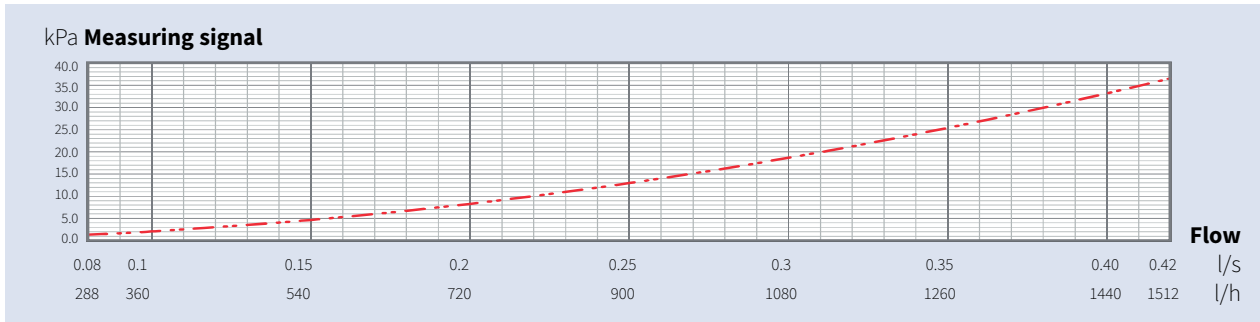

**DN 20S - female/female**

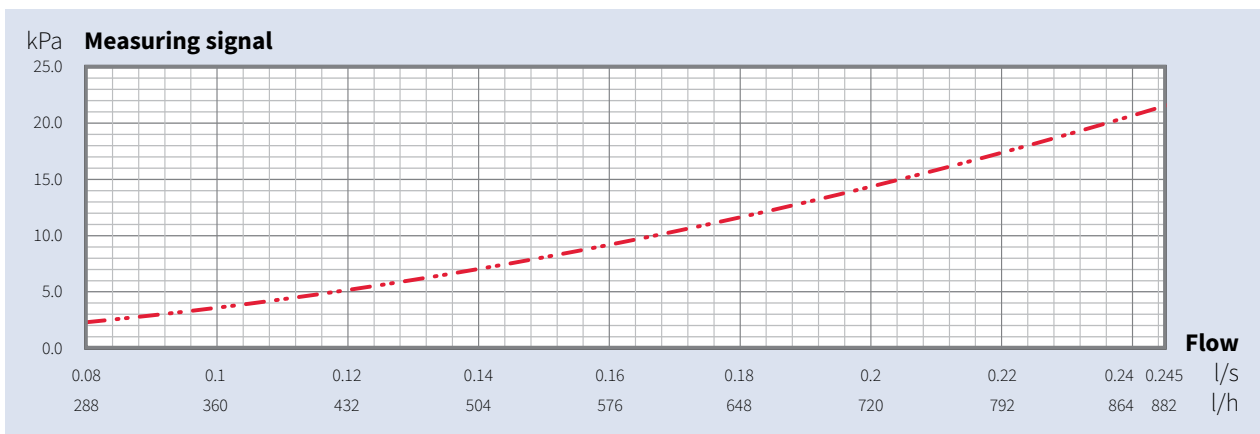

**DN 20H - female/female**

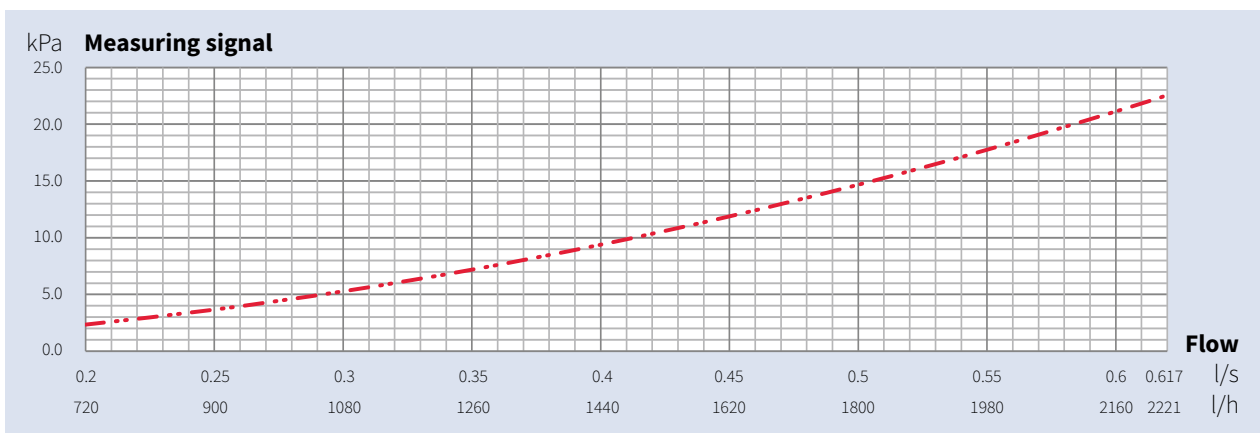

# 4. Product data sheet

## DN 25S - female/female

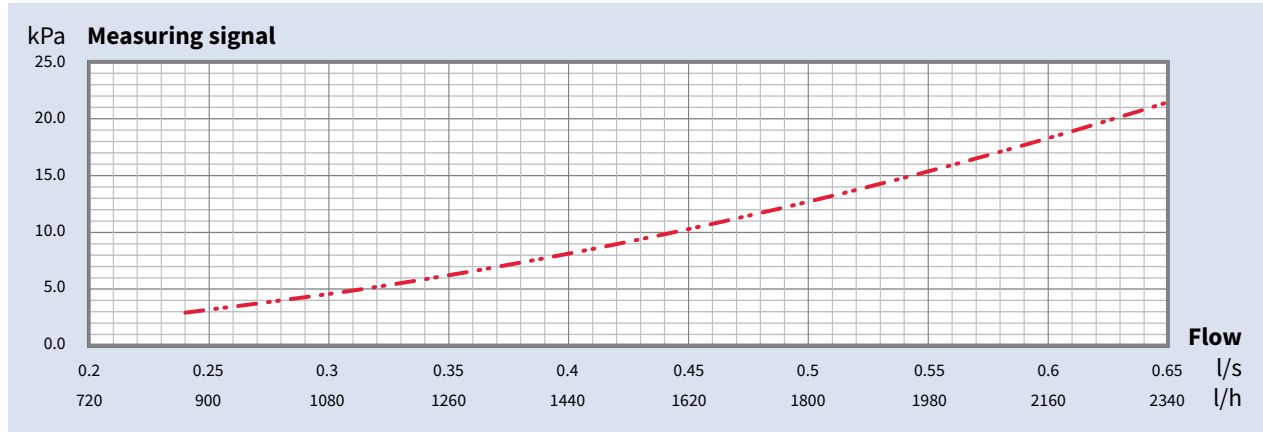

## DN 25H - female/female

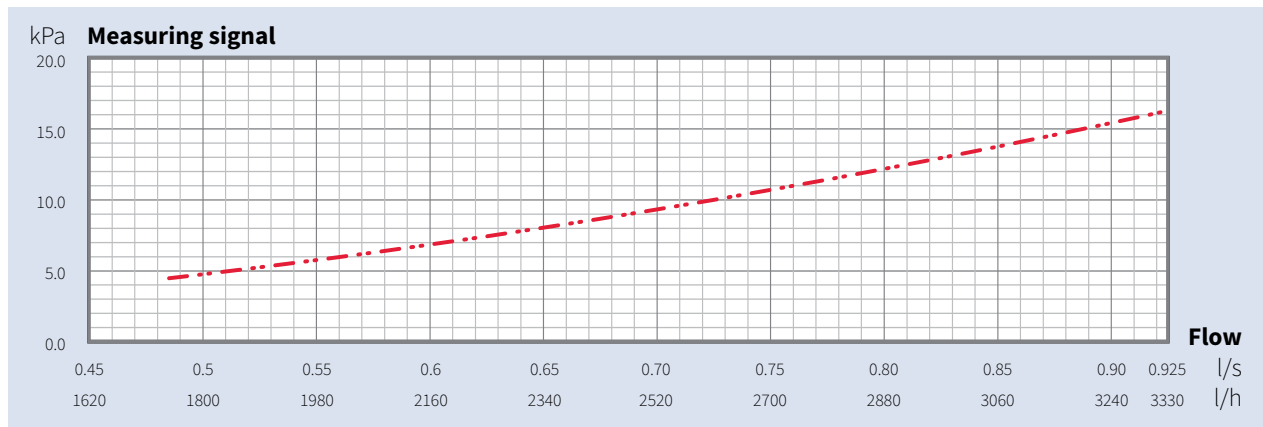

## DN 32H - female/female

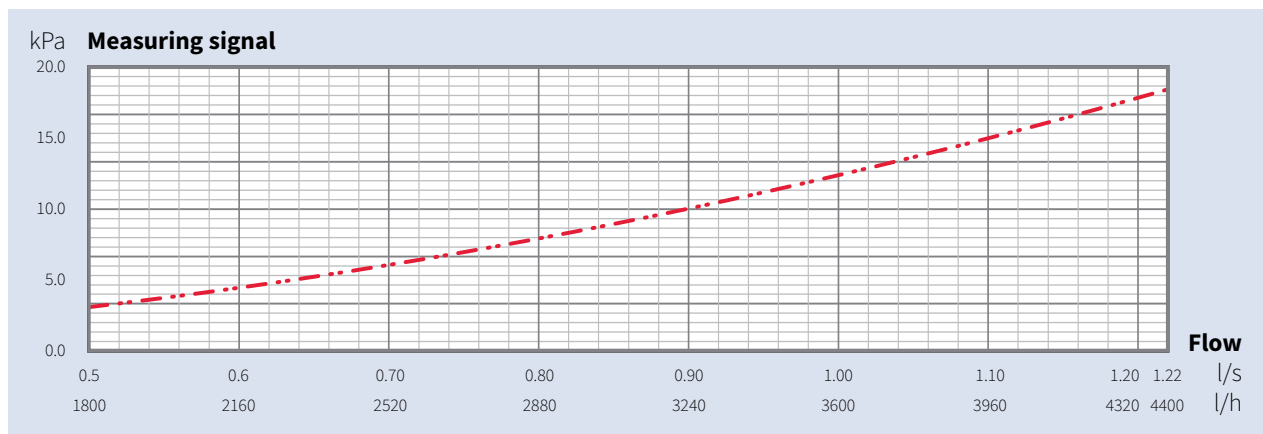



**DN 40S - female/female**

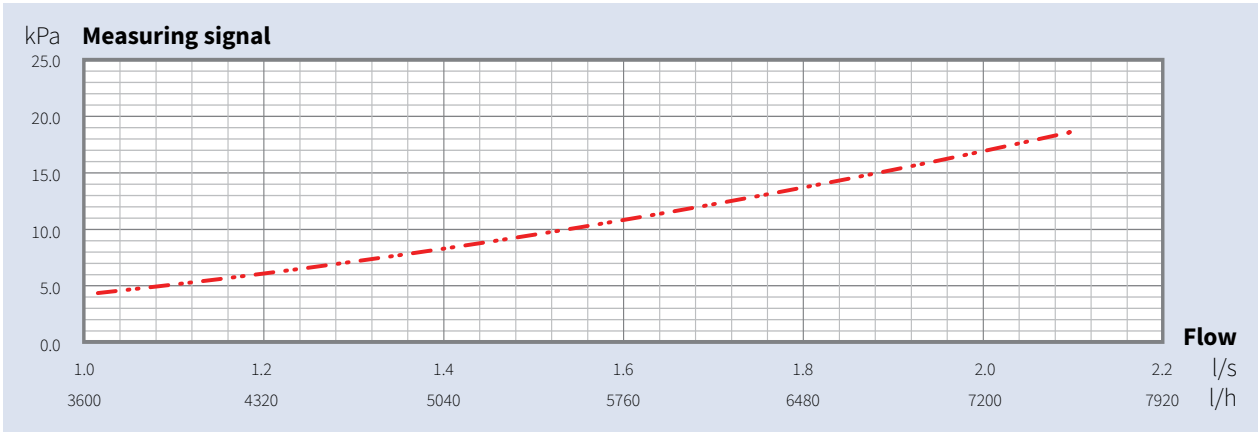

**DN 50H - female/female**

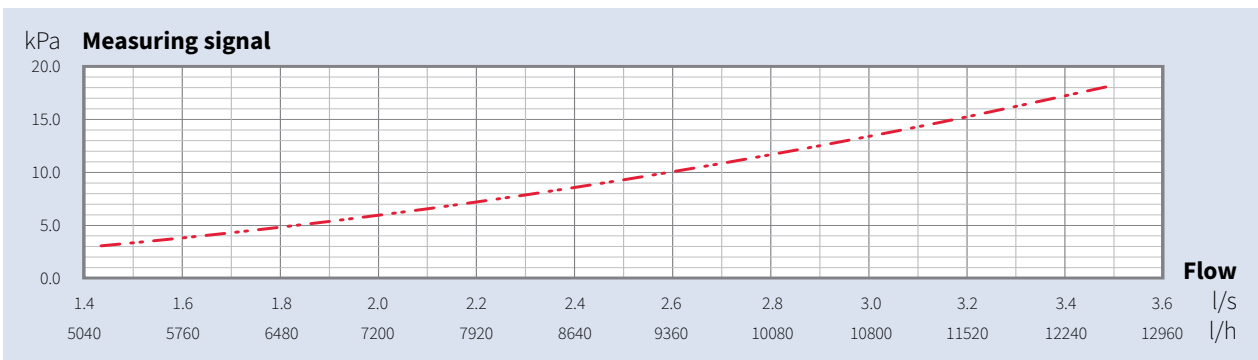

## 5. Accessoires

There is a wide range of accessories and spare parts available for NexusValve Vivax valves.

These comprise

Accessories	Article	Dimension	Description
	MN80597.0016	DN 15	Valve housing with pre-setting cap
	MN80597.0046	DN 20	
	MN80597.0066	DN 25	
	MN80597.0086	DN 32	
	MN80597.0106	DN 40	
	MN80597.0136	DN 50	
	MN80597.0015	DN 15L	White colour - low flow control device
	MN80597.0025	DN 15S	Red colour - standard flow control device
	MN80597.0035	DN 15H	Black colour - high flow control device
	MN80597.0045	DN 20S	White colour - standard flow control device
	MN80597.0055	DN 20H	Black colour - high flow control device
	MN80597.0065	DN 25S	White colour - standard flow control device
	MN80597.0075	DN 25H	Black colour - high flow control device
	MN80597.0085	DN 32H	Black colour - high flow control device
	MN80597.0105	DN 40S	White colour - standard flow control device
	MN80597.0135	DN 50H	Black colour - high flow control device
	MN80597.129	DN 15, DN 20	Ball valve set ¾ thread for Vivax T
	MN80597.130	DN 25	Ball valve set 1 thread for Vivax T
	MN80597.0023	-	Modulating actuator 24 V (0-10 V control voltage) for valves DN 15-25
	MN80597.0037	-	Modulating actuator 24V (0-10 V control voltage and 0-10 V feedback signal) for valves DN15-25
	MN80597.0021	-	On/off actuator 230 V for valves DN 15-25
	MN80597.0022	-	On/off actuator 24 V for valves DN 15-25
	MN80597.0027	-	Modulating actuator 24 V (0-10 V control voltage) for valves DN 15-32
	MN80597.0028	-	3-point floating actuator 24 V for valves DN 15-32
	MN80597.0029	-	3-point floating actuator 230 V for valves DN 15-32

Accessories	Article	Dimension	Description	
	MN80597.0113	-	Modulating actuator 24 V (0-10 V control voltage) for valves DN 40-50	
	MN80597.0115	-	On/off actuator 230 V for valves DN 40-50	
	MN80597.0114	-	On/off actuator 24 V for valves DN 40-50	
	MN80597.0010	DN 15	Insulation jacket	
	MN80597.0040	DN 20		
	MN80597.0060	DN 25		
	MN80597.0080	DN 32		
	MN80597.0100	DN 40		
	MN80597.0130	DN 50		
		MN80597.0011		M30 × 1,5
MN80597.0001		15 mm × ½"	Pre-sealed press adaptors (2 pcs), max. 16 bar	
MN80597.0002	18 mm × ½"			
	MN80597.0005	22 mm × ¾"		
	MN80597.0006	28 mm × 1"		
	MN80597.0007	35 mm × 1¼"		
	MN80597.0008	42 mm × 1½"		
	MN80597.0009	54 mm × 2"		
	MN80597.0205	DN 15		High capacity drain valve (Kv 4,5) ½" female/female threaded connection
	MN80597.0206	DN 20		High capacity drain valve (Kv 4,5) ¾" female/female threaded connection
	MN80597.0207	DN 25	High capacity drain valve (Kv 4,5) 1" female/female threaded connection	

## 6. Sizing examples

### 6.1 NexusValve Vivax system sizing

NexusValve Vivax valves are in the following example installed in a system of fan coil units. The valves will provide the required flow to the terminal units to control the indoor temperature.

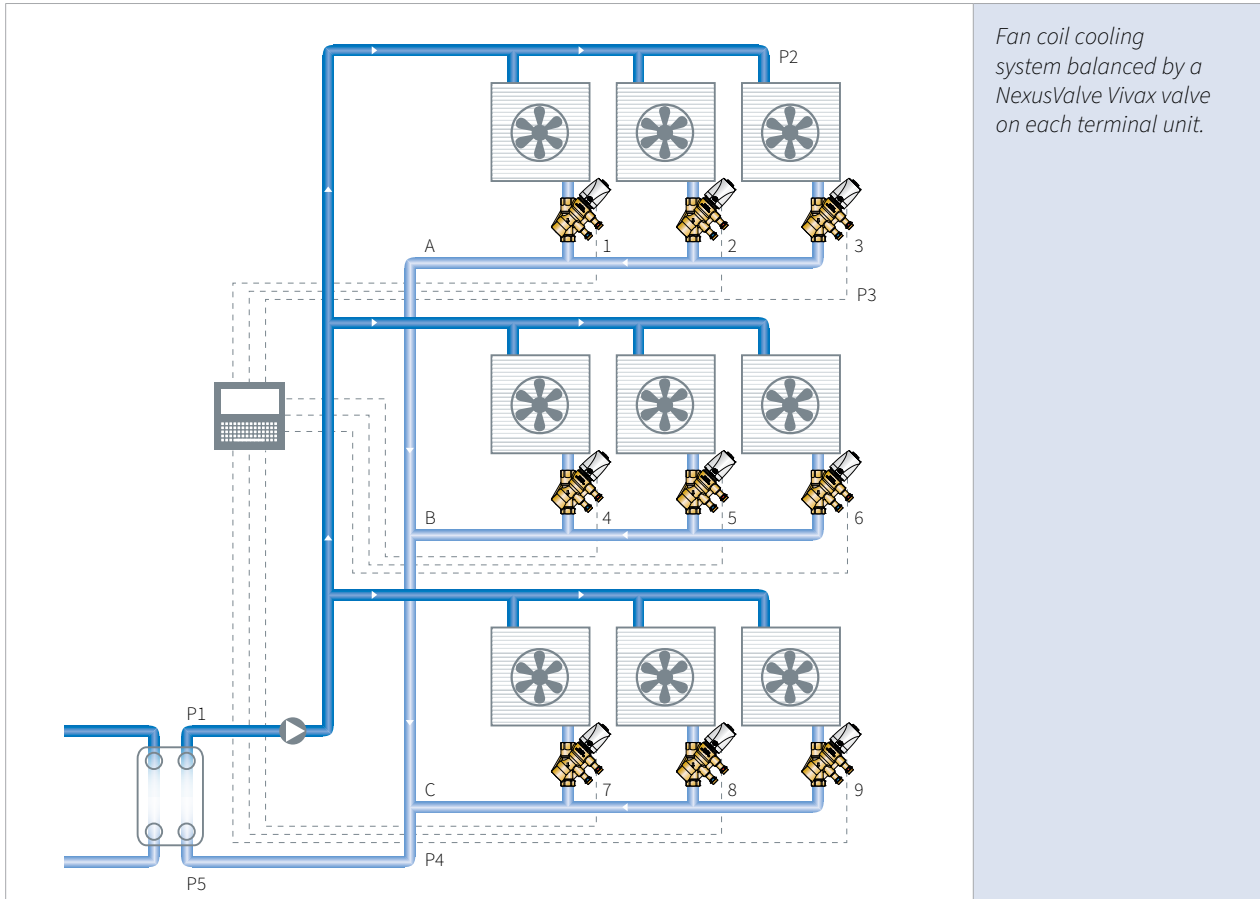

*Fan coil cooling system balanced by a NexusValve Vivax valve on each terminal unit.*

**The fan coil flow specified for the sizing conditions is as follows:**

NexusValve Vivax No. 1: required flow 0.014 l/s (50 l/h)  
 NexusValve Vivax No. 2: required flow 0.020 l/s (72 l/h)  
 NexusValve Vivax No. 3: required flow 0.025 l/s (90 l/h)

NexusValve Vivax No. 4: required flow 0.30 l/s (1080 l/h)  
 NexusValve Vivax No. 5: required flow 0.35 l/s (1260 l/h)  
 NexusValve Vivax No. 6: required flow 0.40 l/s (1440 l/h)

NexusValve Vivax No. 7: required flow 0.50 l/s (1800 l/h)  
 NexusValve Vivax No. 8: required flow 1.00 l/s (3600 l/h)  
 NexusValve Vivax No. 9: required flow 1.10 l/s (3960 l/h)

For the No. 1 NexusValve Vivax valve the required flow is within a NexusValve Vivax DN 15L valve flow range. To find the DN 15L valve setting, a vertical line is drawn from the flow axis (0.014 l/s) to the black curve. Subsequent a horizontal line is drawn from the point of the intersection of the vertical line with the curve to the setting axis. The valve setting then reads 21% to obtain a flow of 0.014 l/s in the NexusValve Vivax valve No. 1.

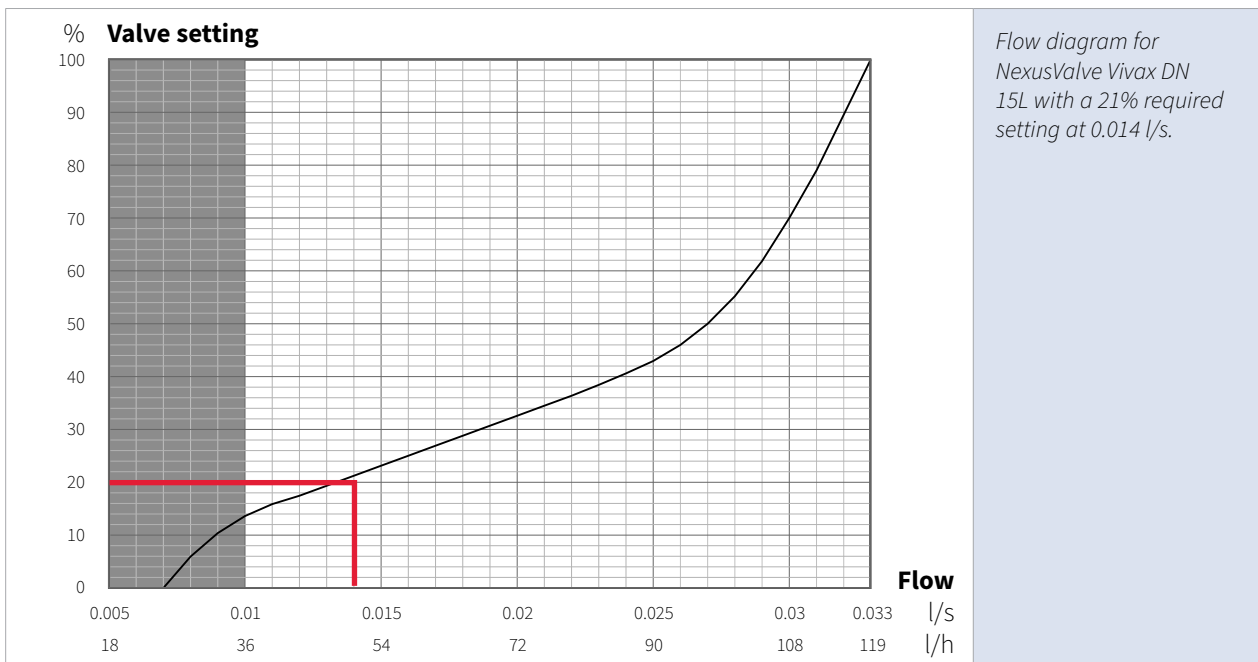

**The setting for the remaining NexusValve Vivax valves is as follows:**

NexusValve Vivax No. 2: DN 15L - setting 33%

NexusValve Vivax No. 3: DN 15L - setting 43%

NexusValve Vivax No. 4: DN 15H - setting 48%

NexusValve Vivax No. 5: DN 15H - setting 65% or DN20H - setting 28%

NexusValve Vivax No. 6: DN 20H - setting 42%

NexusValve Vivax No. 7: DN 20H - setting 65% or DN25S - setting 64%

NexusValve Vivax No. 8: DN 32H - setting 50%

NexusValve Vivax No. 9: DN 32H - setting 67%

During system commissioning the flow can be adjusted by means of the setting tool or more precisely using a NexusValve flowmeter. When using any other flowmeter, the Kvm value must be typed into the flowmeter to receive the correct flow reading.

## 6. Sizing examples

The pressure loss across the measuring points of the No. 1 NexusValve Vivax valve at the flow of 0.014 l/s must be 5.0 kPa.

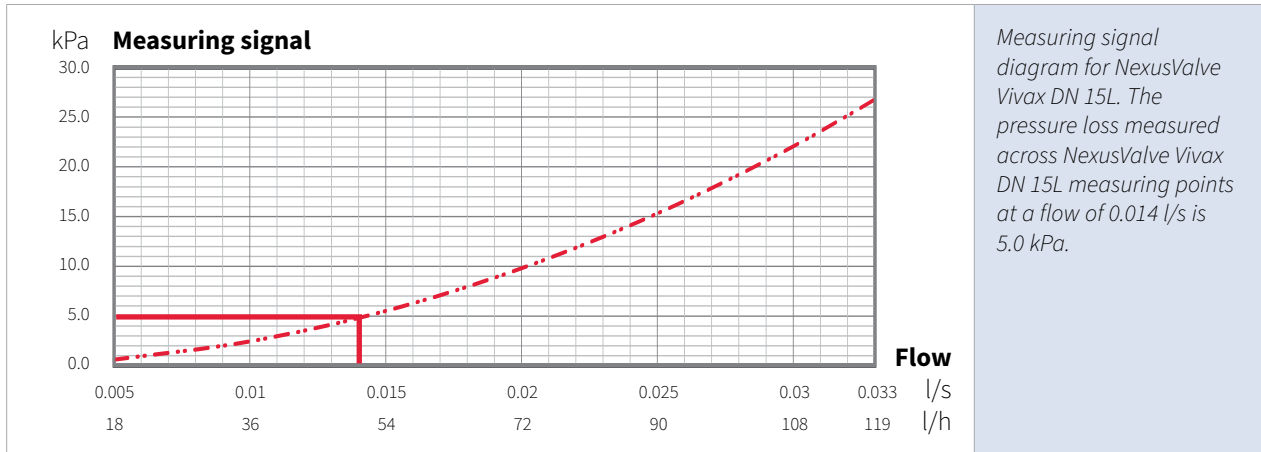

**The same principle applies to the remaining valves in this example. In order to obtain the required flow the following pressure loss across the measuring points of the valves must be obtained:**

NexusValve Vivax No. 2 measuring signal: 9.0 kPa  
 NexusValve Vivax No. 3 measuring signal: 15.0 kPa

NexusValve Vivax No. 4 measuring signal: 19.0 kPa  
 NexusValve Vivax No. 5 measuring signal: 25.5 kPa  
 NexusValve Vivax No. 6 measuring signal: 9.5 kPa

NexusValve Vivax No. 7 measuring signal: 14.5 kPa  
 NexusValve Vivax No. 8 measuring signal: 18.5 kPa  
 NexusValve Vivax No. 9 measuring signal: 22.5 kPa

Knowing that fan coil No. 3 is in the reference circuit, the pump head can be calculated. The pump pressure must be equal to the sum of pressure loss generated in the heat exchanger, pipes, service valves, strainers, fan coil, etc. In addition 30.0 kPa ( $\Delta P_b$ ) required for the NexusValve Vivax is to be added. If the pressure loss calculated along the circuit P1, P2, P3, P4, P5, P1 equals  $\Delta P_C = 35.0$  kPa, the pump head  $\Delta P_h$  must be at least:

$\Delta P_h = \Delta P_C + \Delta P_b = 35.0 + 30.0$  kPa = 65.0 kPa. If a variable speed pump is used, it is to be operated in a constant differential pressure mode (65.0 kPa) to provide the NexusValve Vivax valves with at least 30 kPa differential pressure at all times.

Balancing valves are not required in A, B and C branches. The NexusValve Vivax valves installed at the terminal units will ensure the hydronic balance in the whole system.

**Ordering:**

- NexusValve Vivax No. 1, 2, 3 Article No.: MN80597.001
- NexusValve Vivax No. 4, 5 Article No.: MN80597.003
- NexusValve Vivax No. 6, 7 Article No.: MN80597.005
- NexusValve Vivax No. 8, 9 Article No.: MN80597.008

## 6.2 General specifications DN 15L-50H

### 1 Pressure independent flow control valve NexusValve Vivax

- 1.1. The contractor must install the pressure independent control valves where indicated in drawings.

### 2. Function

- 2.1. The valve must be usable with/or without actuator, either as a dynamic flow limiter or a pressure independent control valve.
- 2.2. The positioning of valve housing with thermo-electric actuator must be possible in any direction (360°).
- 2.3. Flushing through valve with the flow control device removed from the housing must be possible.
- 2.4. Direct flow measuring must be possible at all times with an accuracy tolerance of within  $\pm 3\%$ .
- 2.5. The pre-setting of the valve must have no effect on the valve authority.
- 2.5. Maximum flow setting must be externally adjustable.
- 2.6. The valve must have no requirement for straight up- or downstream piping.

### 3. Valve Body

- 3.1. The valve body must be made of hot stamped DR brass CW602N CuZn36Pb2As.
- 3.2. The pressure rating must be no less than PN25.
- 3.3. A flow arrow must be indicated on the valve body.
- 3.4. Flow pre-setting, actuator and the measuring points must be positioned on the same side of the housing.
- 3.5. Flow measuring through the measuring points must be possible in all valve directions (360°).

### 4. Flow regulation unit

- 4.1. The flow regulation unit must consist of glass-reinforced polyphenylene sulphide.
- 4.2. The flow regulation unit must be of flow control device type for easy accessibility, system flushing, replacement or maintenance.
- 4.3. The flow regulation unit must be easily identifiable and color-coded.
- 4.4. Flow measurement must be done across a flow control device comprising an integrated Fluctus nozzle.

### 5. Actuator

- 5.1. The thermo-electric actuator must be rated IP54 (waterproof).
- 5.2. The electromechanical actuator must be rated IP40.
- 5.3. Actuator must be driven by 24 V or 230 V operating voltage.
- 5.4. Actuator must use full stroke providing full authority.
- 5.5. Actuator must have visible indication of stroke position.

## 7. Actuators

### 7.1 Thermoelectric Actuator for NexusValve Vivax DN 15-25



#### 7.1.1 Description

The thermoelectric actuator is used to operate NexusValve Vivax DN 15 -25 valves. The actuator is controlled by a room thermostat, with two-point output, pulse-width modulation, 0-10V DC signal or a building management system (BMS). The actuator is provided as normally closed in the following versions:

- modulating 0-10V DC signal, 24V AC with 0-10V feedback signal
- modulating 0-10 V DC signal, 24 V AC
- on/off 24 V AC/DC
- on/off 230 V

The actuator mechanism is made up of a PTC resistor – a heated wax element – and a compression spring. The wax element is heated by applying the operating voltage and thereby moving the integrated piston. The force generated by this movement is transferred to the piston to open or close the NexusValve Vivax valve.

#### 7.1.2 Benefits

- Small dimensions
- First-open function
- Maintenance free
- Function display
- Noiseless
- Low power consumption
- 360° installation position
- Long expected service life
- Protection class IP54



### 7.1.3 Design

The thermoelectric actuator can be used with NexusValve Vivax DN 15-25. The installation of the actuator is done by mounting the adaptor onto the valve. The actuator is then clicked onto the adaptor.



The actuator is delivered in open position before electricity is applied for a first-open function. This enables the operation of the heating or cooling system during the construction phase before electrical wiring is completed. During the later electrical start-up, the first-open function is unlocked by applying the operating voltage for more than 6 minutes. The actuator will thereafter be completely operable.

The first-open function of the actuator is not designed for system filling or flushing. It is recommended to remove the flow control device from the valve housing before system flushing. To fill the system the actuator must be removed.



The function display is designed for verification of the valve position. As the built-in wax element expands or contracts, the function display element moves up or down. The function display element is not to be depressed at any time as this might cause damage to the actuator.



The IP54 class makes it possible to install the actuator in any position. The upside down position is allowed but not recommended as it may shorten life of the actuator in some circumstances.

## 7. Actuators

### 7.1.4 Modulating actuator 24 V

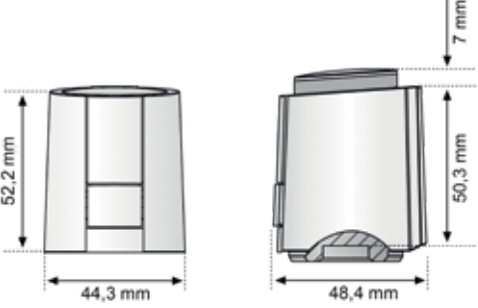
Dimensions	Specifications																								
	<table border="0"> <tr> <td><b>Operating voltage</b></td> <td>24 V AC, 50-60 Hz</td> </tr> <tr> <td><b>Base position</b></td> <td>Normally closed</td> </tr> <tr> <td><b>Operating power</b></td> <td>1 W</td> </tr> <tr> <td><b>Closing and opening time</b></td> <td>3.5min</td> </tr> <tr> <td><b>Control voltage</b></td> <td>0-10 V DC</td> </tr> <tr> <td><b>Actuator travel</b></td> <td>4 mm</td> </tr> <tr> <td><b>Actuating force</b></td> <td>100 N ±5%</td> </tr> <tr> <td><b>Ambient temperature</b></td> <td>0 to +60°C</td> </tr> <tr> <td><b>Protection class</b></td> <td>IP54</td> </tr> <tr> <td><b>CE conformity</b></td> <td>EN 60730</td> </tr> <tr> <td><b>Connecting cable</b></td> <td>White/1 m</td> </tr> <tr> <td><b>Weight with cable</b></td> <td>100g</td> </tr> </table>	<b>Operating voltage</b>	24 V AC, 50-60 Hz	<b>Base position</b>	Normally closed	<b>Operating power</b>	1 W	<b>Closing and opening time</b>	3.5min	<b>Control voltage</b>	0-10 V DC	<b>Actuator travel</b>	4 mm	<b>Actuating force</b>	100 N ±5%	<b>Ambient temperature</b>	0 to +60°C	<b>Protection class</b>	IP54	<b>CE conformity</b>	EN 60730	<b>Connecting cable</b>	White/1 m	<b>Weight with cable</b>	100g
<b>Operating voltage</b>	24 V AC, 50-60 Hz																								
<b>Base position</b>	Normally closed																								
<b>Operating power</b>	1 W																								
<b>Closing and opening time</b>	3.5min																								
<b>Control voltage</b>	0-10 V DC																								
<b>Actuator travel</b>	4 mm																								
<b>Actuating force</b>	100 N ±5%																								
<b>Ambient temperature</b>	0 to +60°C																								
<b>Protection class</b>	IP54																								
<b>CE conformity</b>	EN 60730																								
<b>Connecting cable</b>	White/1 m																								
<b>Weight with cable</b>	100g																								

Actuator	Article	Description
	MN80597.0023	Modulating actuator - 24 V AC operating voltage

The modulating thermo-electric actuator will open or close NexusValve Vivax DN 15-25 valves in direct proportion to the applied control voltage. The control is powerless and is achieved by use of a 0-10 V DC signal which is provided either by a room thermostat or by a building management system (BMS). When a control voltage is applied, the actuator opens the valve proportionally to the detected actuator travel.

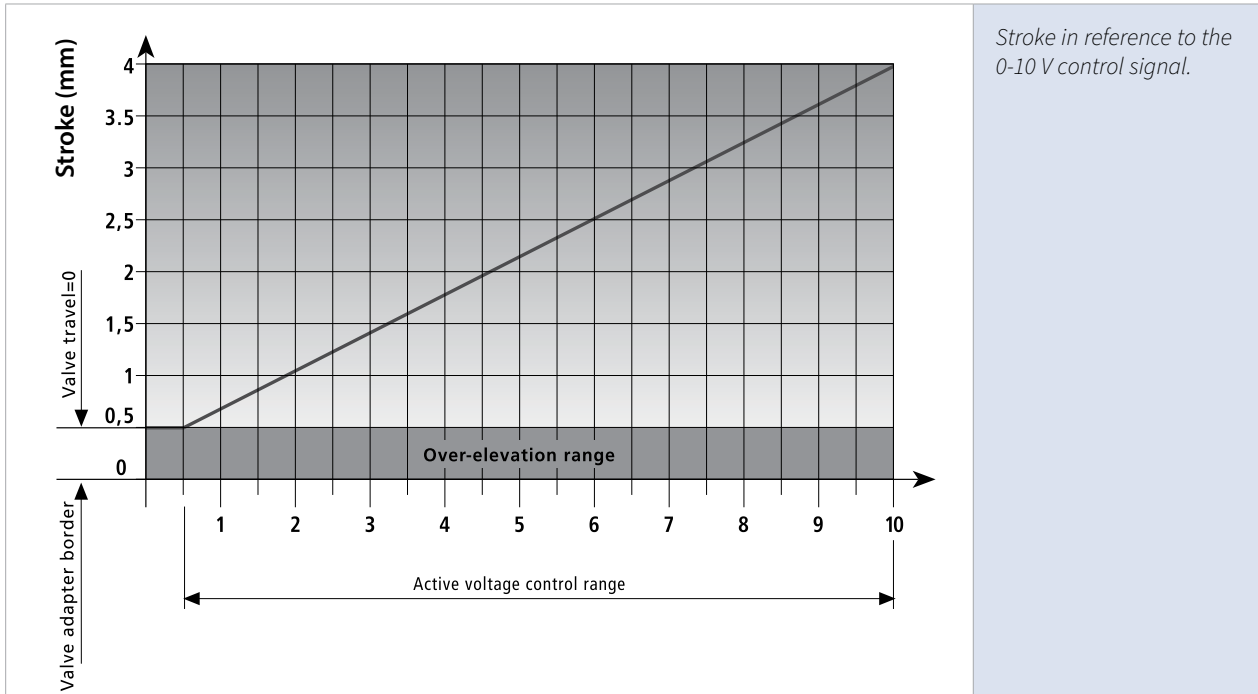

The NexusValve Vivax actuator normally remains closed. The valve is opened once by 0.5 mm and then closes again after applying the operating voltage of 24 V AC. This is done as a first-open function to unlock and to find the closing point of the valve. This ensures an optimum match with the valve.

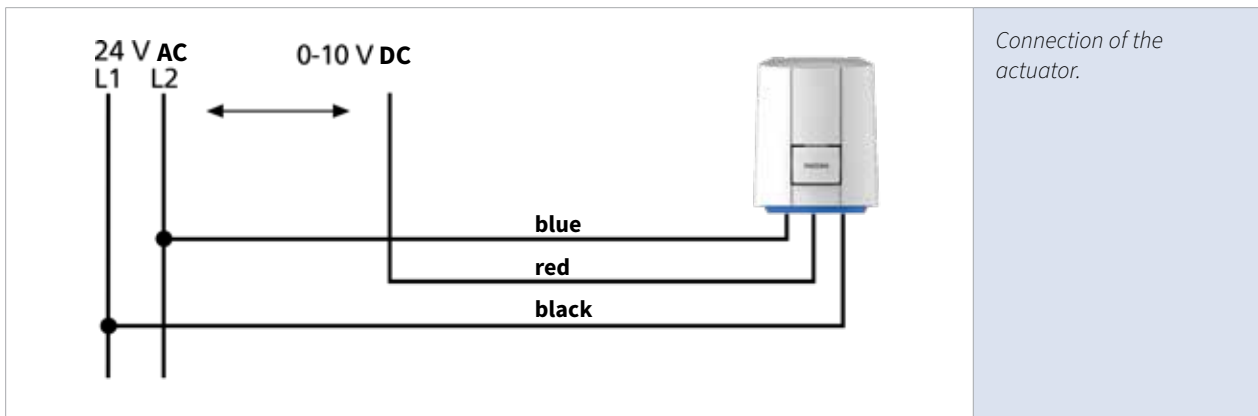

## 7. Actuators

### 7.1.5 Modulating actuator 24 V with feedback signal

Dimensions	Specifications
	<p><b>Operating voltage</b> 24 V AC, 50-60 Hz</p> <p><b>Base position</b> Normally closed</p> <p><b>Operating power</b> 1.2 W</p> <p><b>Closing and opening time</b> 3.5min</p> <p><b>Feedback signal</b> 0-10 V DC</p> <p><b>Actuator travel</b> 6.5 mm</p> <p><b>Actuating force</b> 100 N ±5%</p> <p><b>Ambient temperature</b> 0 to +60°C</p> <p><b>Protection class</b> IP54</p> <p><b>CE conformity</b> EN 60730</p> <p><b>Connecting cable</b> White/1 m</p> <p><b>Weight with cable</b> 111g</p>

Actuator	Article	Description
	MN80597.0037	Modulating actuator - 24 V AC operating voltage

The modulating thermo-electric actuator will open or close NexusValve Vivax DN 15-25 valves in direct proportion to the applied control voltage. The control is powerless and is achieved by use of a 0-10 V DC signal which is provided either by a room thermostat or by a building management system (BMS). When a control voltage is applied, the actuator opens the valve proportionally to the detected actuator travel.

The stroke of the actuator is 6.5mm while the required stroke of the NexusValve Vivax is less than 4.0mm. Thanks to the integrated valve stroke recognition, the valve path is automatically registered for an optimum use of the active control voltage range.

The actuator also provides 0-10V DC feedback signal about the current position of the valve and about possible errors.

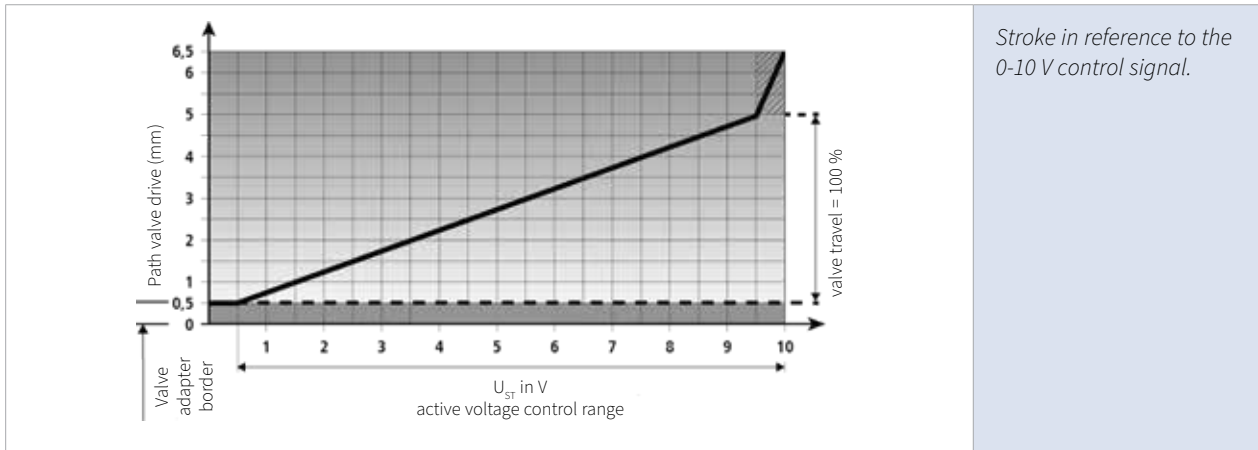

The actuator is delivered in open position for the first-open function. The first-open function is unlocked after switching on the operating voltage for the first time. Subsequently the actuator automatically determines and saves the valve closing point and the valve path and switches to regular operation. The saved values are used for control requirements and for position determination after a voltage interruption. The saved values are checked during the running operation and adapted as needed in order to counteract deviations. This process guarantees an optimum adaptation of the actuator to the valve. In control operation the present control voltage is measured and the actuator precisely moves to the calculated position.

An internal wear-free position detection controls the temperature required for the stroke and consequently the energy intake of the PTC resistor-heated elastic element. No excess energy is stored inside the elastic element. If the control voltage is changed, the electronic control system immediately adapts the heat input to the elastic element. In the range of 0 – 0.5 V the actuator remains in a quiescent state in order to ignore ripple voltage occurring in long cables. The closing force of the compression spring is matched to the closing force of the valve.

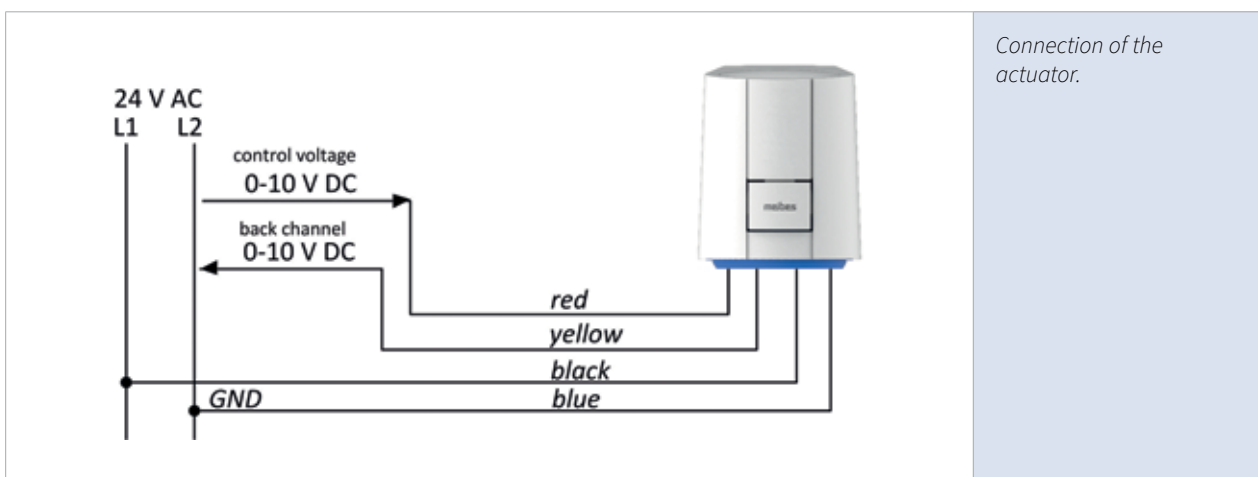

## 7. Actuators

### 7.1.6 ON/OFF actuator 230 V and 24 V

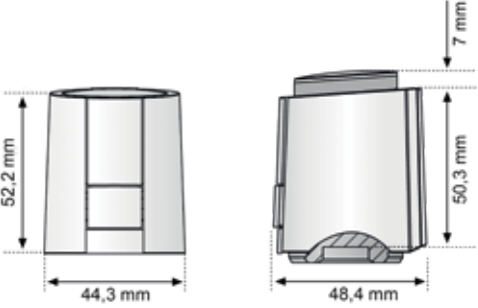
Dimensions	Specifications		
	<b>Operating voltage</b>	24 V AC/DC 50-60 Hz	230 V AC 50-60 Hz
	<b>Base position</b>	Normally closed 1 W	Normally closed 1 W
	<b>Operating power</b>	3.5min	3.5min
	<b>Closing and opening</b>	100 N ±5%	100 N ±5%
	<b>Actuating force</b>	4.0mm	4.0mm
	<b>Ambient temperature</b>	0 to +60°C	0 to +60°C
	<b>Protection class</b>	IP54	IP54
	<b>CE conformity</b>	EN 60730	EN 60730
	<b>Connecting cable</b>	Grey/1 m	Grey/1 m
	<b>Weight with cable</b>	100g	100g

Actuator	Article	Description
	MN80597.0021	ON/OFF actuator - 230 V operating voltage
	MN80597.0022	ON/OFF actuator - 24 V operating voltage

The NexusValve Vivax DN 15-25 valves are opened steadily by the ram motion of the actuator upon switching on the operating voltage and after the expiry of the dead time. The wax element cools down after the operating voltage is cut, and the closing force of the compression spring will close the valve evenly.

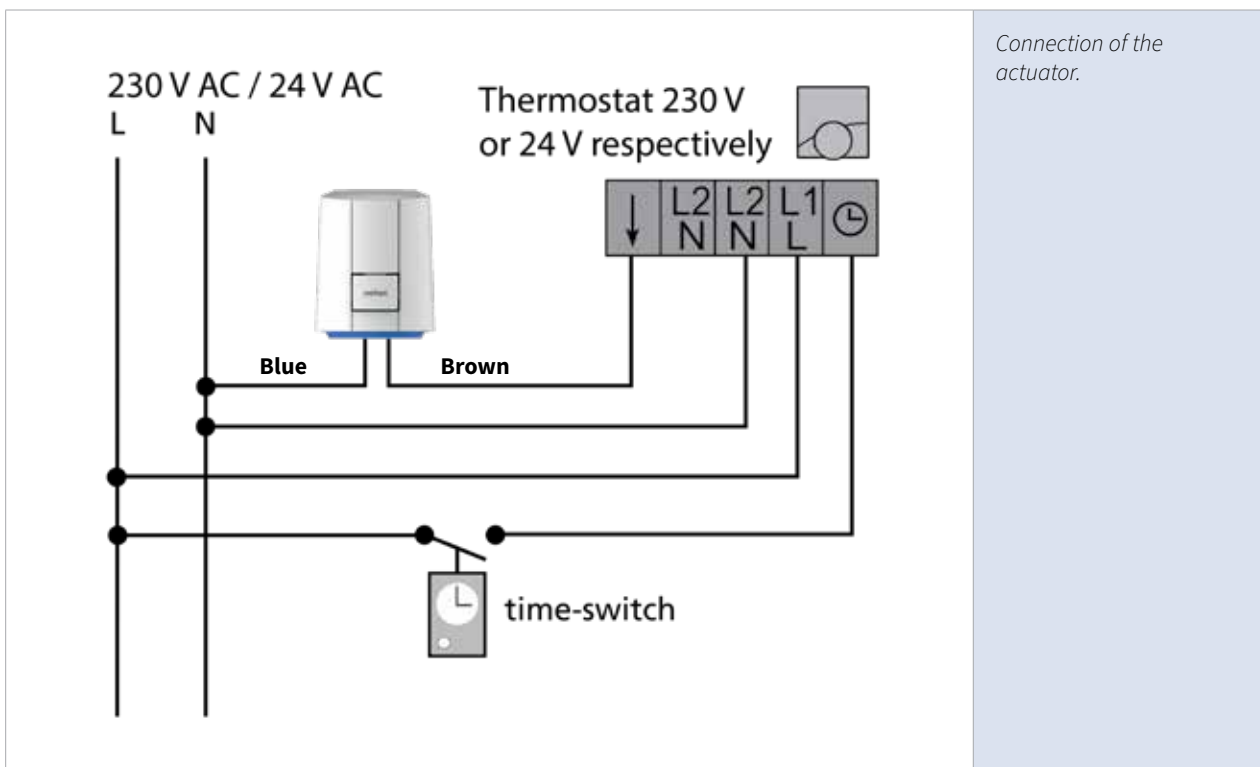
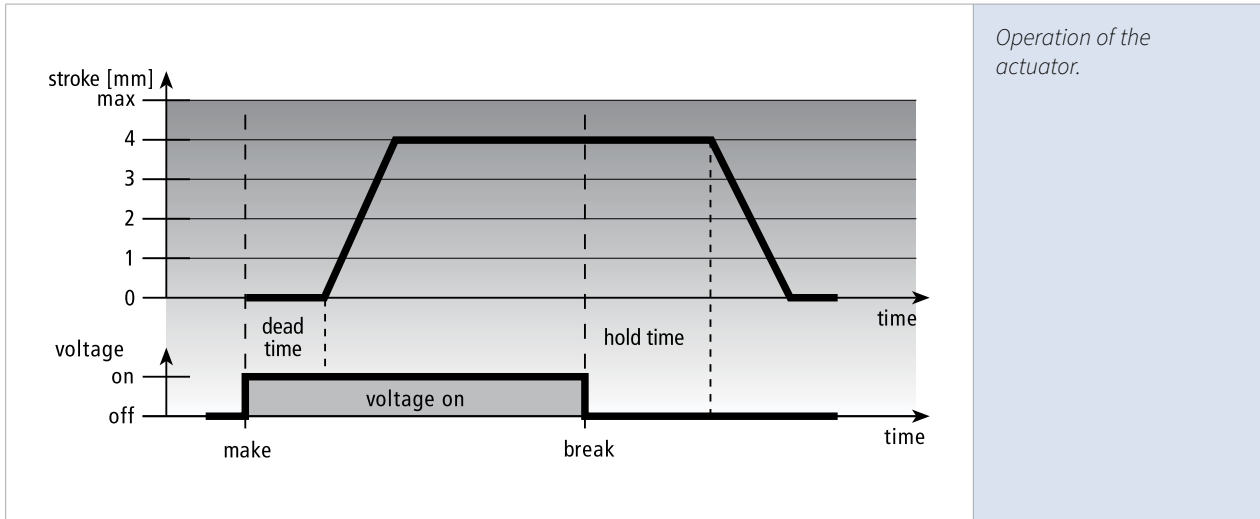

A safety isolating transformer according to EN 61558-2-6 (Europe) must always be used for 24V actuators. Transformer dimensioning results from the making capacity of the actuators.

## 7. Actuators

### 7.2 Electromechanical actuator for NexusValve Vivax DN15-32

	<b>Modulating and 3 point floating actuator</b>
	<b>Electro-mechanical</b>
	<b>NexusValve Vivax DN15-DN32 1/2" – 1 1/4"</b>

#### 7.2.1 Description

The electromechanical actuators for the NexusValve Vivax DN15 - DN32 valves are available in three versions:

- BA-24M - modulating, 24V , controlled by a selectable range of modulating voltage control signals
- BA-24F - 3 point floating, 24V
- BA-230F - 3 point floating, 230V

The actuators have a linear output drive. The BA-24M model is designed for use in combination with any controller providing a direct current output signal. The actuator can be controlled by 0-10V, 6-9V, 1-5V, 2-10V, 4-7V, 6-10V or 8-11V signals. The BA-24F is a 24V AC actuator suitable for controlling a NexusValve Vivax valve from any 24V AC, 3-point controller or device. The BA-230F is a mains voltage 230 V AC actuator to be controlled from any controller or device having a 3-point mains switched output.

#### 7.2.2 Benefits

- Accurate positioning
- DIP switches for stroke selection
- DIP switches for modulating voltage control signals selection
- Wide range of modulating voltage control signals
- Simple installation and commissioning (self refer-encing/auto stroking)
- Direct coupling to valve
- Actuator fitting to the valve without the use of tools
- Stroke indication and manual override on all models
- Compact design easing fitting at terminal units



### 7.2.3 Design

The valve stem movement is produced by rotation of a screw spindle connected, through a gear train, to a synchronous bidirectional motor. An internal magnetic clutch limits the torque on the valve stem, avoiding the use of microswitches and protecting the actuator from overload. Under floating control the actuator should be set to operate at no more than 120% of the valve's full stroke time to save on electrical consumption and noise. The modulating BA-24M uses a micro-processor based high performance positioner to ensure accurate stroke position and flow control in the valve. The close-off position is self-adjusting by means of an automatic synchronization function. Synchronization is carried out when power is switched on and the zero point calibrated when the valves end stop closing limit is reached. All MP200 models allow manual override by means of an Allen key (3 mm). It is necessary to disconnect power to the actuator before operating the manual override. The actuator has a detachable cable for 3-wire electrical connection. The actuator requires no maintenance.

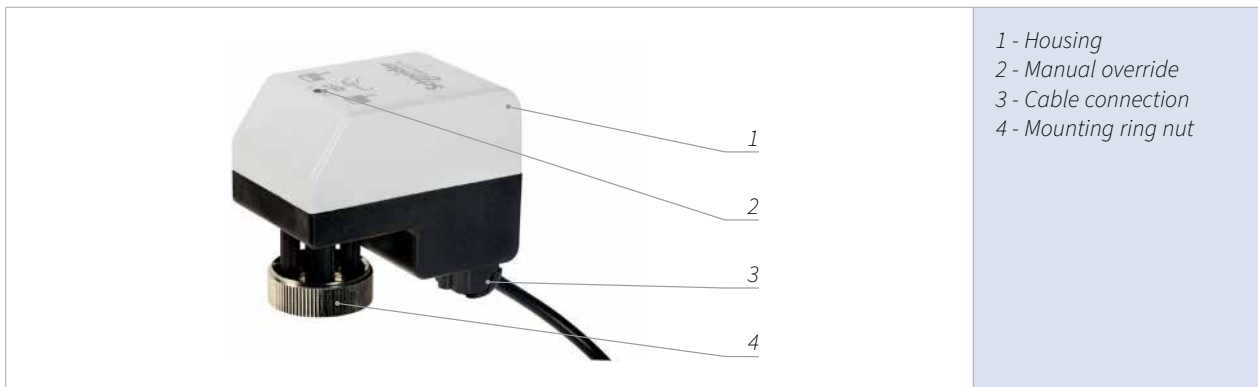

### 7.2.4 Installation

The actuator can be mounted in any position but it is advisable to orientate the installation so that condensation or any potential water leaks cannot enter the housing.

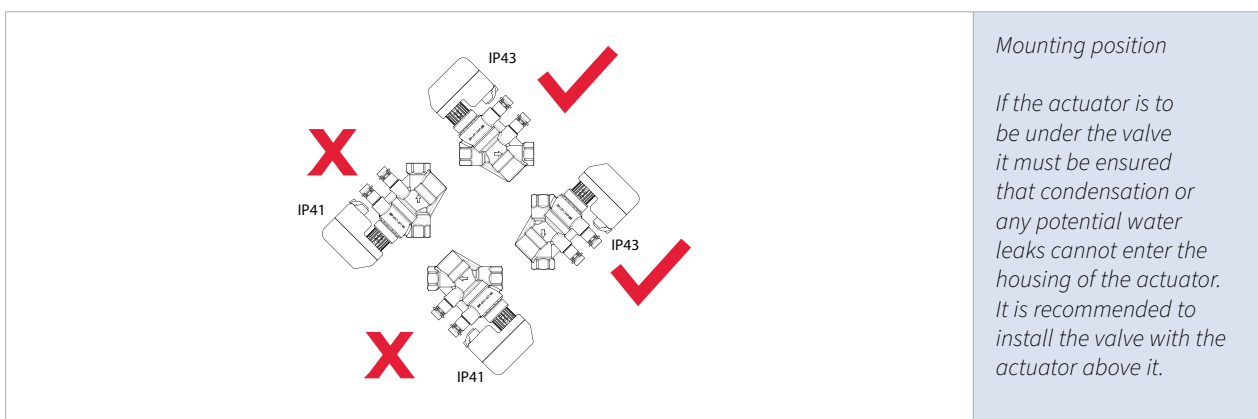

A ring nut M30 x1.5 allows for easy hand coupling to the valve, tools are not necessary and must not be used.

## 7. Actuators

The modulating actuator BA-24M offers a selection of control signal settings. The following control signals can be selected by moving the DIP switches 2 to 8 to ON position:

- 0-10V
- 6-9V
- 1-5V
- 2-10V
- 4-7V
- 6-10V
- 8-11V

Only one switch can be in ON position at a time.

ON	OFF	N. DIP.
3.5mm	5.0mm	1
0..10V	-	2
6..9 V	-	3
1..5V	-	4
2..10 V	-	5
4..7 V	-	6
6..10 V	-	7
8..11 V	-	8

*Control signal and stroke setting*

The stroke of the actuator can be adjusted from 3.5 to 5.0 mm. This is done by moving the DIP switch 1 to ON or OFF position.

The actuator is delivered from factory having the setting of control signal 0-10V and stroke limited to 3,5mm. If the actuator is going to be mounted on NexusValve Vivax DN15-32 the stroke setting must not be changed.

Note: The lower voltage range will extend the actuator screw to close the valve.

Applying power to the actuator before its installation onto the valve is completed will change the pre-set position, and adjustment by the manual override will be required to fit the actuator onto the valve.

## 7.2.5 Modulating actuator 24 V

### Dimensions

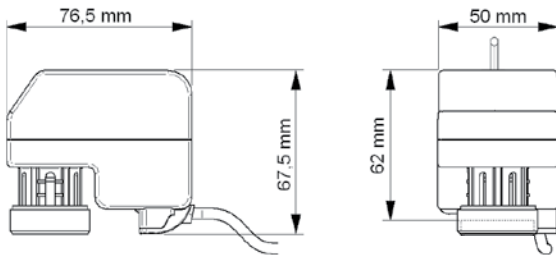

### Specifications

<b>Operating voltage</b>	24 V AC
<b>Operating power</b>	1 VA
<b>Control voltage</b>	adjustable min 0V – max 11V
<b>Actuator stroke</b>	3.5 or 5.0 mm
<b>Stroke time</b>	18s/mm (50)Hz, 15s/mm (60)Hz, 200N
<b>Actuating force</b>	
<b>Ambient temperature</b>	operating -5 to 50°C storage -25 to 65°C
<b>Protection class</b>	IP 43/41
<b>Ambient humidity</b>	0 - 95%
<b>Weight</b>	162g
<b>CE conformity marked to the following directives</b>	- EMC 2004/108/CE to EN 61326-1 - LVD 2006/95/CE to EN 61010-1 standard for 230V products

### Actuator



### Article

MN80597.0027

### Description

BA-24M - modulating actuator  
24 V AC operating voltage

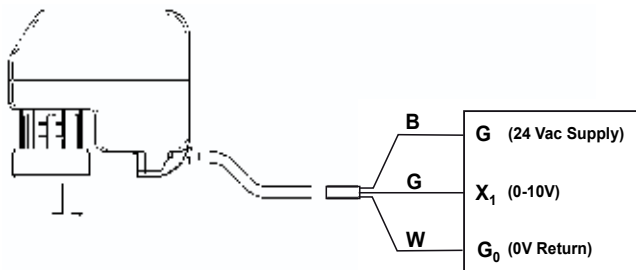



Connection of the actuator

B - brown  
G - green  
W - white

# 7. Actuators

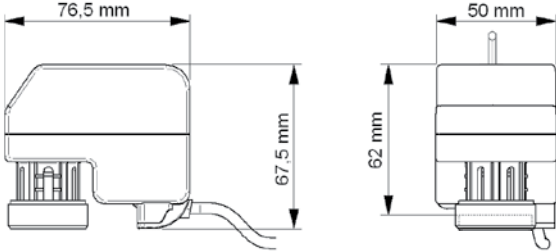
## 7.2.6 3 point floating actuator 24V

Dimensions	Specifications
	<p><b>Operating voltage</b> 24 V AC  <b>Operating power</b> 0.7 VA  <b>Actuator stroke</b> 3.5 or 5.0 mm  <b>Stroke time</b> 18s/mm (50)Hz, 15s/mm (60)Hz,  <b>Actuating force</b> 200N  <b>Ambient temperature</b>            operating -5 to 50°C            storage -25 to 65°C  <b>Protection class</b> IP 43/41  <b>Ambient humidity</b> 0 - 95%  <b>Weight</b> 162g  <b>CE conformity marked to the following directives</b></p> <ul style="list-style-type: none"> <li>- EMC 2004/108/CE to EN 61326-1</li> <li>- LVD 2006/95/CE to EN 61010-1 standard for 230V products</li> </ul>

Actuator	Article	Description
	MN80597.0028	BA-24F – 3 point floating actuator 24 V AC operating voltage

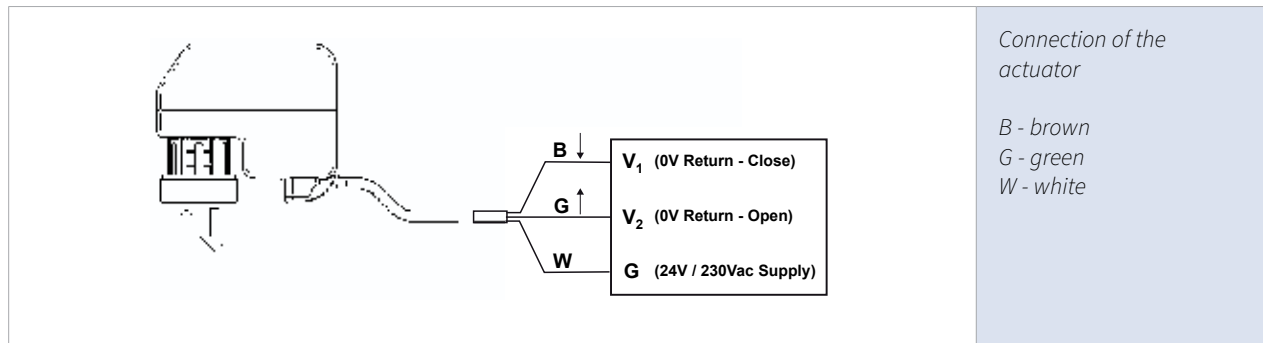

### 7.2.7 3 point floating actuator 230V

#### Dimensions

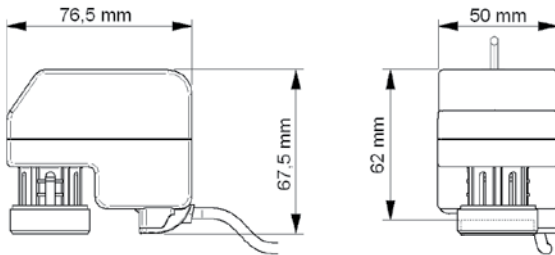

#### Specifications

<b>Operating voltage</b>	230 V AC
<b>Operating power</b>	0.7 VA
<b>Actuator stroke</b>	3.5 or 5.0 mm
<b>Stroke time</b>	18s/mm (50)Hz, 15s/mm (60)Hz,
<b>Actuating force</b>	200N
<b>Ambient temperature</b>	operating -5 to 50°C storage -25 to 65°C
<b>Protection class</b>	IP 43/41
<b>Ambient humidity</b>	0 - 95%
<b>Weight</b>	162g
<b>CE conformity marked to the following directives</b>	- EMC 2004/108/CE to EN 61326-1 - LVD 2006/95/CE to EN 61010-1 standard for 230V products

#### Actuator



#### Article

MN80597.0029

#### Description

BA-230F – 3 point floating actuator  
230 V AC operating voltage

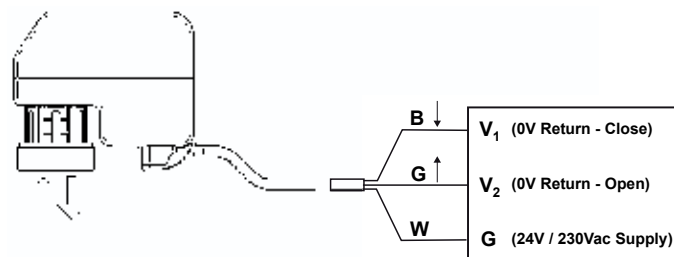

*Connection of the actuator*

*B - brown  
G - green  
W - white*

## 7. Actuators

### 7.3 Electromechanical actuator for valves DN 15-32

	<b>Modulating actuator</b>
	<b>Electro-mechanical</b>
	<b>NexusValve Vivax DN 15 - DN 32 1/2" - 1 1/4"</b>

#### 7.3.1 Description

The NexusValve MPO is an electro-mechanical, 0-10V DC modulating, 24V AC actuator with 0-10V DC feedback signal. It is factory configured to fit on NexusValve Vivax DN15-32.

The NexusValve MPO comprises an LCD with background illumination for displaying the operation data and an LED to indicate the operation state. The actuator offers a manual override for servicing purposes and can be protected against theft by means of the removable locking latch.

#### 7.3.2 Benefits

- LCD for displaying operation information
- LED for operation state indication
- Removable cable
- Different cable length available as separate kit (up to 20m)
- Very low standby power consumption
- Maximum energy efficiency due to complete motor control via micro controller
- Self-locking gear when de-energized
- Antitheft construction
- Force-dependent deactivation in case of overload or when the closing position is reached
- Protection class IP 54 - installation in any position is allowed
- Low-noise and maintenance-free

### 7.3.3 Design

NexusValve MPO actuator comprises 24V stepper motor, an intelligent micro controller and a gear mechanism. The force generated by the motor is transferred via the gear mechanism to the valve pressing plate, thus opening or closing the valve. The actuator is provided with an adaptor to enable the mounting on the valve. The actuator is supplied from the factory with the valve pressing plate in retracted position.

NexusValve MPO actuator is controlled by 0-10 V DC signal generated by a room thermostat or a BMS system. At 0 V the valve is closed, and at 10 V it is completely opened.

The NexusValve MPO comprises an LCD with background illumination for displaying the current stroke, the control voltage, and the operating modes (open/close), as well as error codes.

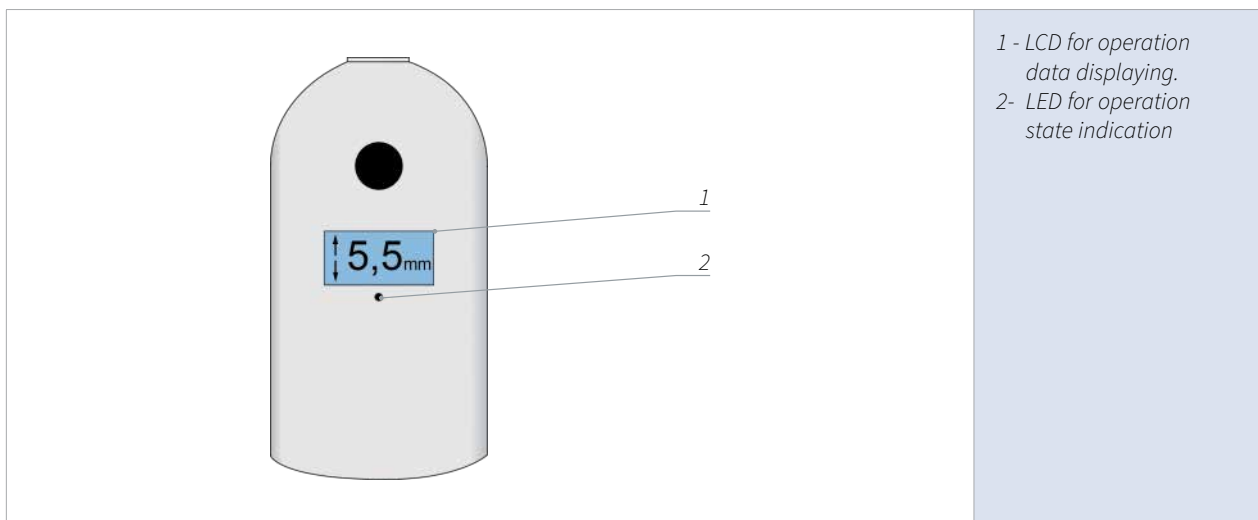

The actuator is also provided with bi-coloured LED for indicating the operation state. A green flashing light indicates normal operation while a continuous red light indicates a fault.

The NexusValve MPO offers a manual override for servicing purposes. The manual operation of the actuator is allowed after disconnecting power supply. By inserting a 4mm Allen key into the manual override slot and rotating it the pressing plate is moved in the desired direction to either open or close the valve.

## 7. Actuators

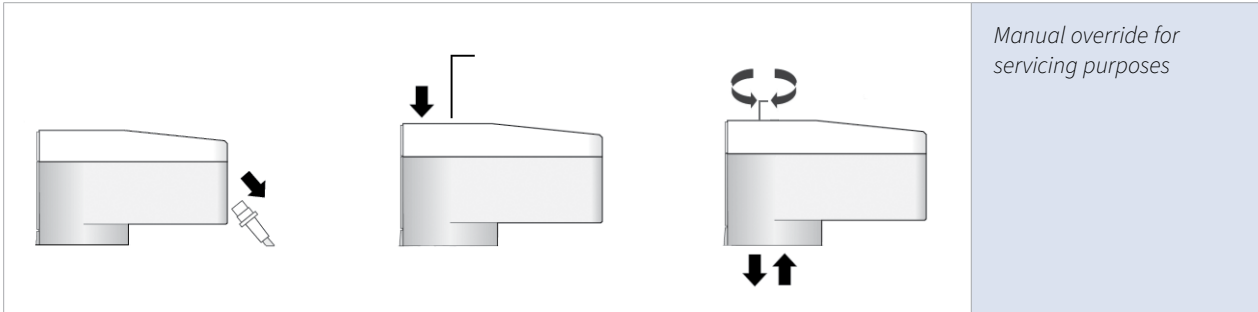

*Manual override for servicing purposes*

The NexusValve MPO can be controlled with 0-10V DC signal or with pulse width modulation (PWM) which secures an easy integration into building control systems. The PWM switching frequency can be configured in the factory in the range from 100Hz to 1000Hz.

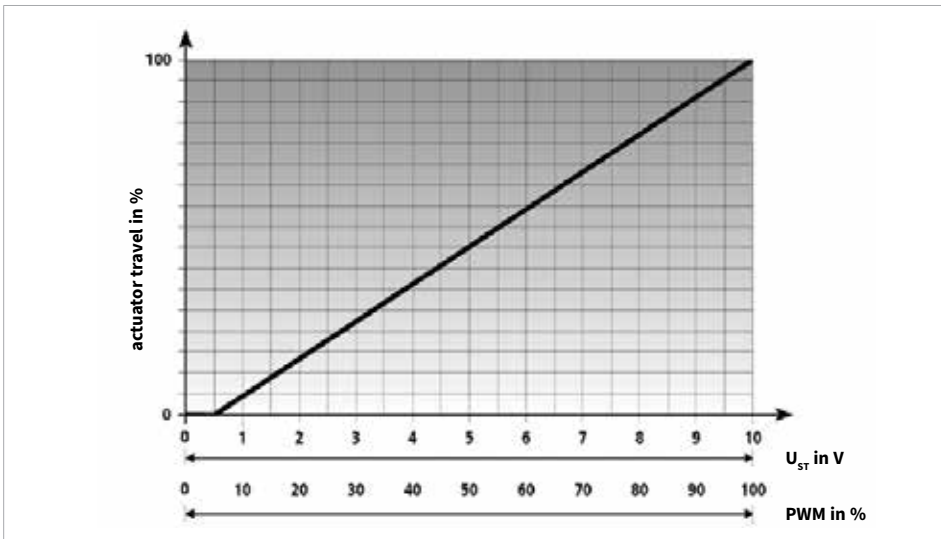

*Control signal*

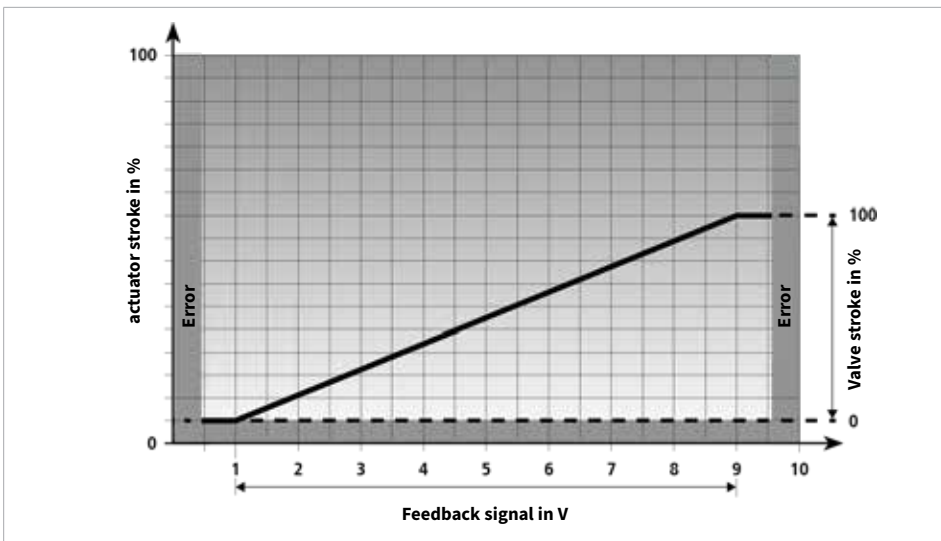

*Feedback signal:*

- < 0,5 V: no operation or no contact
- 1V to 9V: feedback signal proportional to the valve travel
- 1V: valve closed
- 9V: valve opened
- > 9,5 V: internal error



### 7.3.4 Installation

In order to mount the actuator an adaptor is needed. The adaptor is provided along with the actuator and needs to be mounted on the valve first. Subsequently the actuator is pushed onto the adaptor till a click sound is heard.

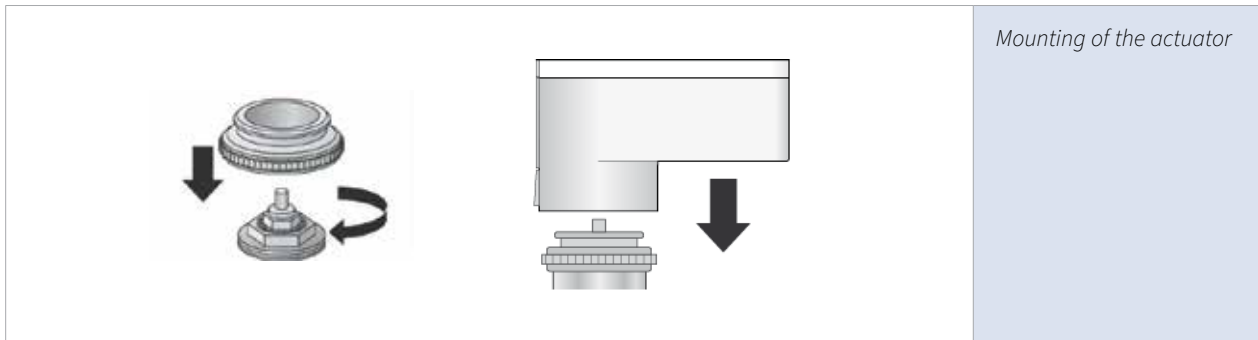

The NexusValve MPO is equipped with a plug-in connection line. When the cable is disconnected from an actuator which is mounted on a valve in a system the IP class is affected and the actuator has to be protected against water penetration.

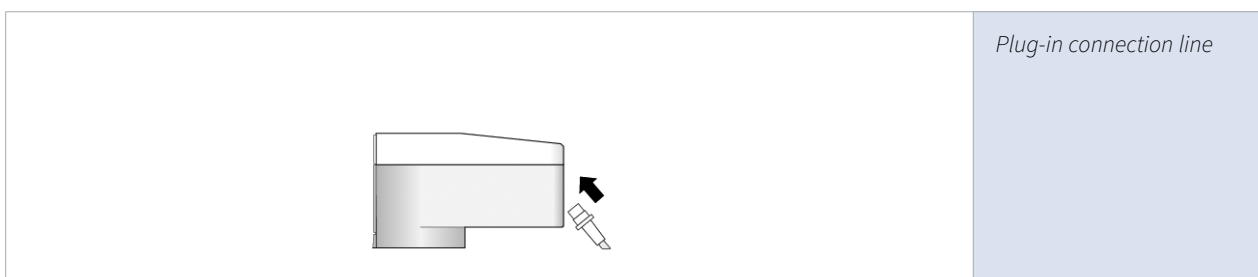

The actuator is protected against theft by means of the removable locking latch. If the actuator is to be removed the latch needs to be pressed and the actuator pulled up. When the latch is removed the access to the actuator becomes significantly more difficult for the ones who are not authorized.



The NexusValve MPO is produced in IP54 protection class. Consequently mounting the actuator in any position is allowed. The upside down position is not recommended in wet environment as water spillage from drain valves etc. can reduce the life time of the actuator.

## 7. Actuators

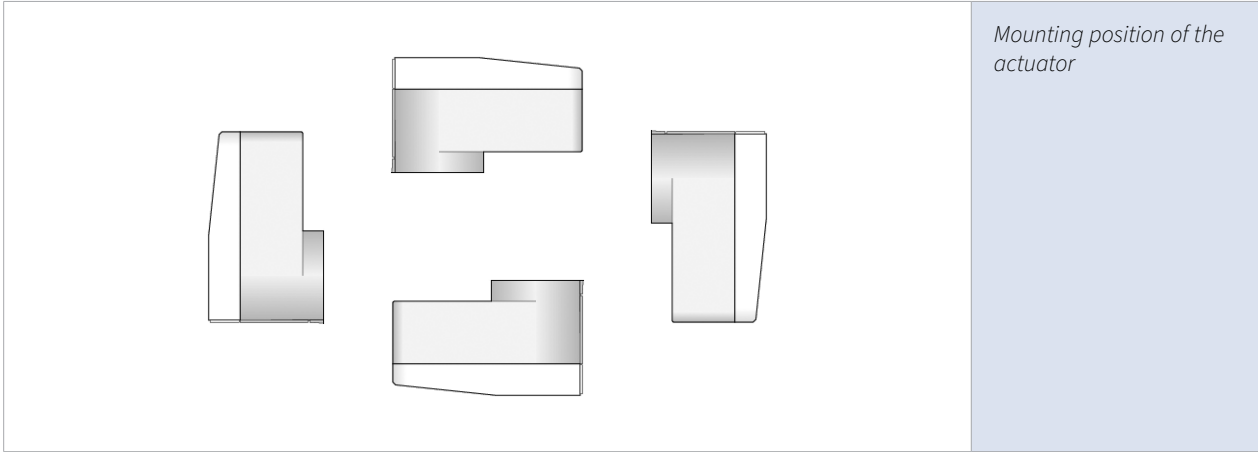

### 7.3.5 Modulating actuator 24 V

#### Dimensions

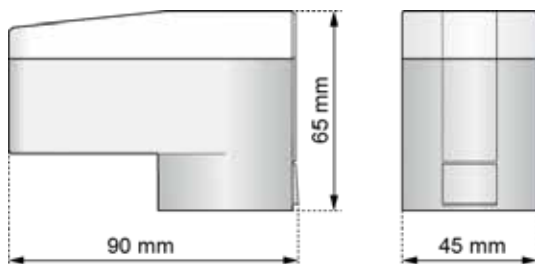

#### Specifications

<b>Operating voltage</b>	24 V AC, 50-60Hz 24V DC
<b>Operating power</b>	2,4 VA
<b>Control signal</b>	0-10V DC
<b>Feedback signal</b>	0-10V DC
<b>Actuator stroke</b>	3,3mm max 8,5mm
<b>Running time</b>	30s/mm
<b>Actuating force</b>	200N
<b>Ambient temperature</b>	operating -0 to 50°C storage -20 to 70°C
<b>Protection class</b>	IP54
<b>Weight</b>	155g
<b>CE conformity marked to the following normative</b>	EN 60730
<b>UL tested</b>	UL60730-1: 2009/R:2013-11 UL60730-2-14: 2013-02

#### Actuator



#### Article

MN80597.0036

#### Description

NexusValve MPO  
24 V AC / DC operating voltage  
0-10V DC control signal and  
0-10V DC feedback signal.

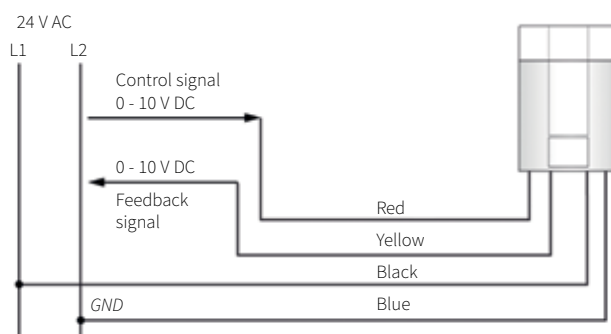

*Connection of the actuator*

## 7. Actuators

### 7.4 Electromechanical Actuator for NexusValve Vivax DN 40-50

	<b>ON/OFF and modulating actuator</b>
	<b>Electro-mechanical</b>
	<b>NexusValve Vivax DN 40 - 50 1½ - 2”</b>

#### 7.4.1 Description

The electromechanical actuators for the NexusValve Vivax DN 40 - 50 valves are available in three versions:

- AVUE - modulating controlled by 0-10 V DC signal 24 V AC
- AVUX - on/off 24 V AC
- AVUM - on/off 230 V AC

The AVUE actuator has a linear output drive for use in combination with any controller providing a 0-10 V direct current (DC) output signal to operate a NexusValve Vivax DN 40 - 50 valve. The AVUX is a 24 V alternating current (AC) modulating linear actuator suitable for modulating a NexusValve Vivax valve from any 24 V (AC), 3-point controller or device. The AVUM is a mains voltage (230 V AC) modulating linear actuator to be controlled from any controller or device having a 3-point mains switched output.

#### 7.4.2 Benefits

- Accurate positioning
- Simple installation and commissioning (self-referencing/auto stroking)
- Direct coupling to valve
- Actuator fitting to the valve without the use of tools
- Built-in manual override supplied as standard (screwdriver operated for security)
- Neat compact design easing fitting at terminal units
- Fly lead simplifying wiring to the controller
- Approved to European EMC and safety standards
- Manual Override Reset facility (AVUE)
- 0-10 V DC control signal input (AVUE)
- 3-point modulating signal (AVUX & AVUM)
- LEDs for indicating the current operating state (on variant MN80597.0113)

### 7.4.3 Design

The electromechanical actuators for NexusValve Vivax DN 40 - 50 valves operate by a screw jack principle using a reversible synchronous motor via a gear train and a magnetic clutch.

Installation instructions:

The actuator can be installed on the NexusValve Vivax with the help of the installation kit. (See separate installation instructions)



## 7. Actuators

### 7.4.4 Installation

The actuator cover is not to be removed when installing the actuator onto the NexusValve Vivax DN 40 - 50 valves. It is required that the two captive fixing screws in the mounting frame are fully retracted prior to the installation. The adapter, factory mounted on the valve, is then slid into the claw coupling. The actuator frame is lowered onto the valve until it is even with the valve clamping face. The two captive screws are then finally finger tightened (tools are not required). The claw coupling should already be in the optimum position, but if this is not the case, the manual override must be adjusted on the top of the unit (a small, flat-blade screwdriver will be required; turning the screw clockwise will drive the claw coupling down). The AVUE actuator has a reset button on the underside to be used when the manual override is operated at the unit powered-up. Minimum 100 mm space above the actuator is required.

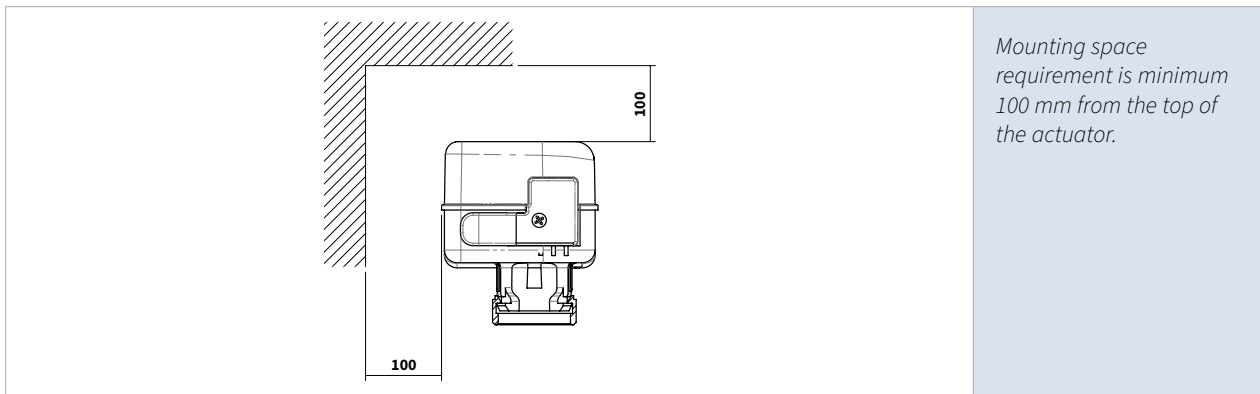

*Mounting space requirement is minimum 100 mm from the top of the actuator.*

The colour-coded fly lead is connected to the controller, as shown in the appropriate connection diagram. Cable length and resistance limitations must be observed.

Wiring from actuator to controller	Max. length 1.5 mm cable unshielded	Max. resistance per conductor
AVUE 0-10 V DC signal	100 m	50Ω
AVUM - 230 V AV	100 m	10Ω

*Wiring pre-cautions.*

It must be ensured the cable is routed clear of valve and pipework.

Applying power to the actuator before its installation onto the valve is completed will change the pre-set position, and adjustment by the manual override will be required to fit the actuator onto the valve.

### 7.4.5 Modulating actuator 24 V

#### Dimensions

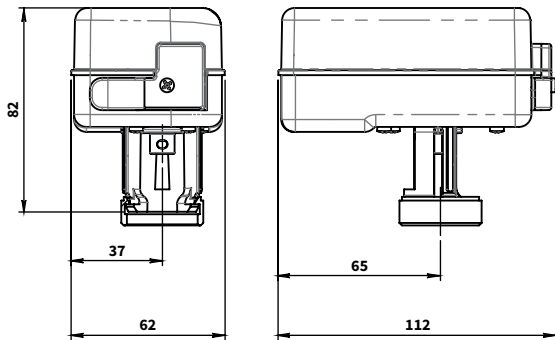

#### Specifications

<b>Operating voltage</b>	24 V AC
<b>Operating power</b>	3.6 VA
<b>Control voltage</b>	0 - 10 V DC
<b>Stroke time</b>	11,5 s/mm
<b>Actuating force</b>	300 N
<b>Ambient temperature</b>	
operating	-5 - 55 °C
storage	-25 - 65 °C
<b>Protection class</b>	IP43
<b>Connecting cable</b>	1.5 m long, 5 core
<b>CE conformity</b>	EN 60730-1

#### Actuator



#### Article

MN80597.0113

#### Description

AVUE - modulating actuator -  
24 V operating voltage

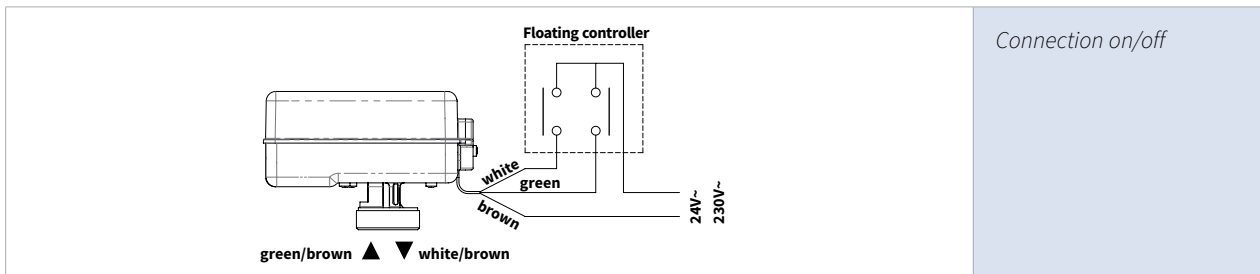

Connection on/off

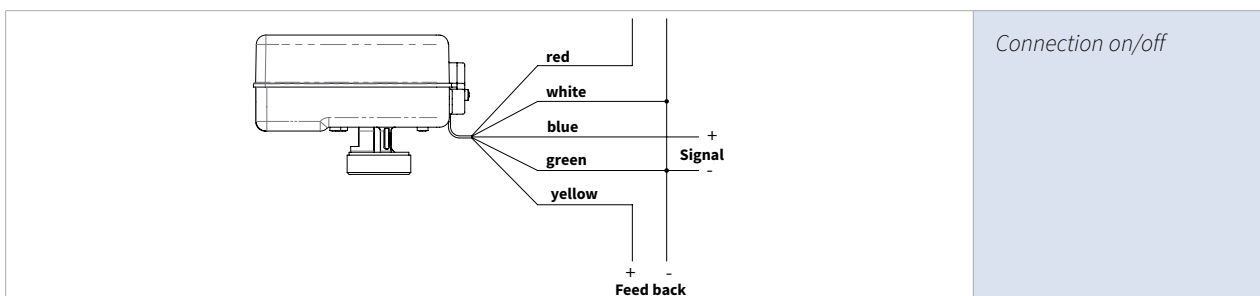

Connection on/off

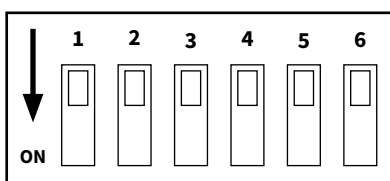

DIP 1 ON = INV action / stroke  
DIP 2 ON = 2-10 / 6-10  
DIP 3 ON = Range SEQ  
DIP 4 ON = fixed stroke  
DIP 5 ON = 4-20mA  
DIP 6 ON = Learning / stroke

OFF = DIR action / stroke  
OFF = 0-10 / 0-5  
OFF = Range NORM  
OFF = auto calibr. stroke  
OFF = voltage range  
OFF = Running / stroke

# 7. Actuators

## 7.4.6 ON/OFF actuator 230 V

Dimensions	Specifications
	<p><b>Operating voltage</b> 230 V AC  <b>Operating power</b> 16.2 VA  <b>Control voltage</b> 230 V AC  <b>Stroke time</b> 11.5 s/mm  <b>Actuating force</b> 300 N  <b>Ambient temperature</b>            operating -5 - 55 °C            storage -25 - 65 °C  <b>Protection class</b> IP43  <b>Connecting cable</b> 1.5 m lang, 3-adrig  <b>CE conformity</b> EN 60730-1</p>

Actuator	Article	Description
	MN80597.0115	AVUM - modulating actuator - 230 V operating voltage

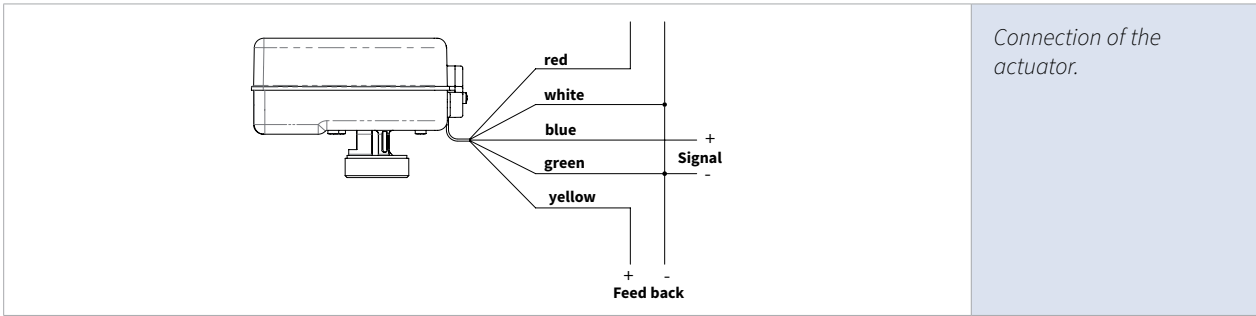
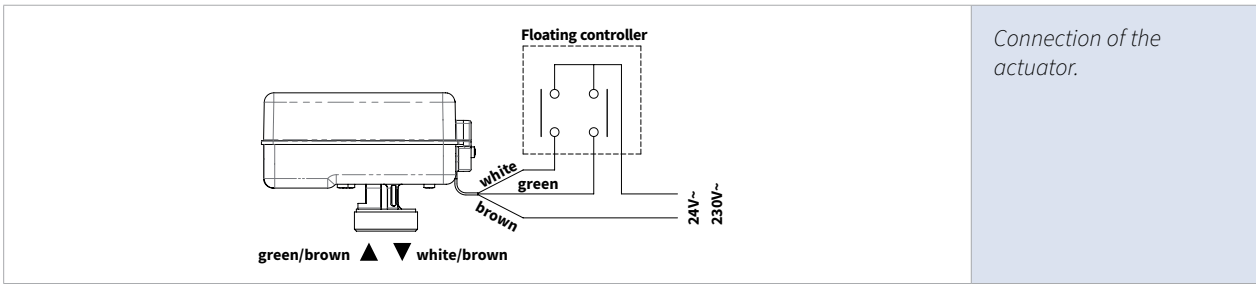



### 7.4.7 ON/OFF actuator 24 V

#### Dimensions

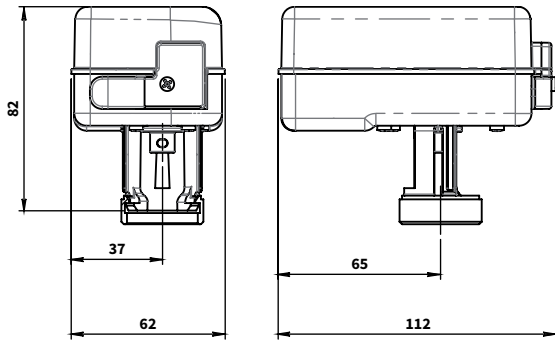

#### Specifications

<b>Operating voltage</b>	24 V AC
<b>Operating power</b>	2.2 VA
<b>Control voltage</b>	24 V AC
<b>Stroke time</b>	11.5 s/mm
<b>Actuating force</b>	300 N
<b>Ambient temperature</b>	
operating	-5 - 55 °C
storage	-25 - 65 °C
<b>Protection class</b>	IP43
<b>Connecting cable</b>	1.5 m lang, 3-adrig
<b>CE conformity</b>	EN 60730-1

#### Actuator



#### Article

MN80597.0114

#### Description

AVUX - ON/OFF actuator -  
24-V-AC operating voltage

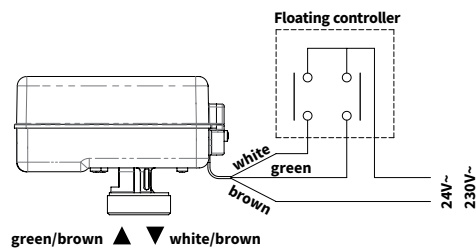

Connection of the  
actuator.

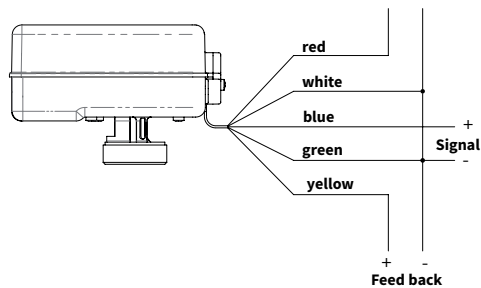

Connection of the  
actuator.



## Contact

### The Netherlands (HQ)

Aalberts hydronic flow control  
+31 36 52 62 300  
info@flamcogroup.com  
info@comap.nl

### China

Flamco Heating Accessories  
(Changshu) Ltd, Co.  
+86 512 528 417 31  
yecho@flamco.com.cn

### Denmark

Flamco Denmark  
+45 44 94 02 07  
info@flamco.dk

### France

Flamco s.a.r.l.  
+33 1 342 191 91  
info@flamco.fr

### Germany

Flamco GmbH  
+49 2104 80006 20  
info@flamco.de

### Italy

Distributore: Commerciale Delta  
+39 (0)2 242 8303  
vendite@commercialedelta.it

### Slovakia

Flamco SK s.r.o.  
+421 475 634 043  
info@meibes.sk

### Sweden

Flamco Sverige  
+46 50 042 89 95  
vvs@flamco.se

### United Arab Emirates

Flamco Middle East  
+971 4 8819540  
info@flamco-gulf.com

### Belgium

Flamco BeLux  
+32 50 31 67 16  
info@flamco.be

### Czech Republic

Flamco CZ s.r.o.  
+420 284 00 10 81  
info@meibes.cz

### Estonia

Flamco Baltic  
+372 568 838 38  
info@flamco.ee

### France

Comap s.a.r.l.  
+33 4 78 78 16 00  
marketing@comap.eu

### Hungary

Flamco Kft  
+36 23 880981  
info@flamco.hu

### Poland

Flamco Meibes Sp. z o.o.  
+48 65 529 49 89  
info@flamco.pl

### Russian Federation

ООО „Майбес РУС“  
+7 495 727 20 26  
moscow@meibes.ru

### Switzerland

Flamco AG  
+41 41 854 30 50  
info@flamco.ch

### Export

Comap International  
+33 4 78 78 16 00  
export.contacts@comap.eu

### Belgium

Comap BeLux  
+32 2 371 01 67  
info@comap.be

### Czech Republic

Comap Praha s.r.o.  
+420 284 860 404  
marketing.praha@comap.eu

### Finland

Flamco Finland  
+358 10 320 99 90  
info@flamco.fi

### Germany

Meibes System-Technik GmbH  
+49 342 927 130  
info@meibes.com

### Hungary

Comap Hungária Kft.  
+36 23 503 871  
comap.hungary@comap.eu

### Poland

Comap Polska Sp. z o.o.  
+48 22 679 00 25  
comap@comap.pl

### Russian Federation

Comap Россия (офис)  
+7 499 703 33 56  
info.rus@comap.eu

### United Kingdom

Flamco Limited  
+44 17 447 447 44  
info@flamco.co.uk

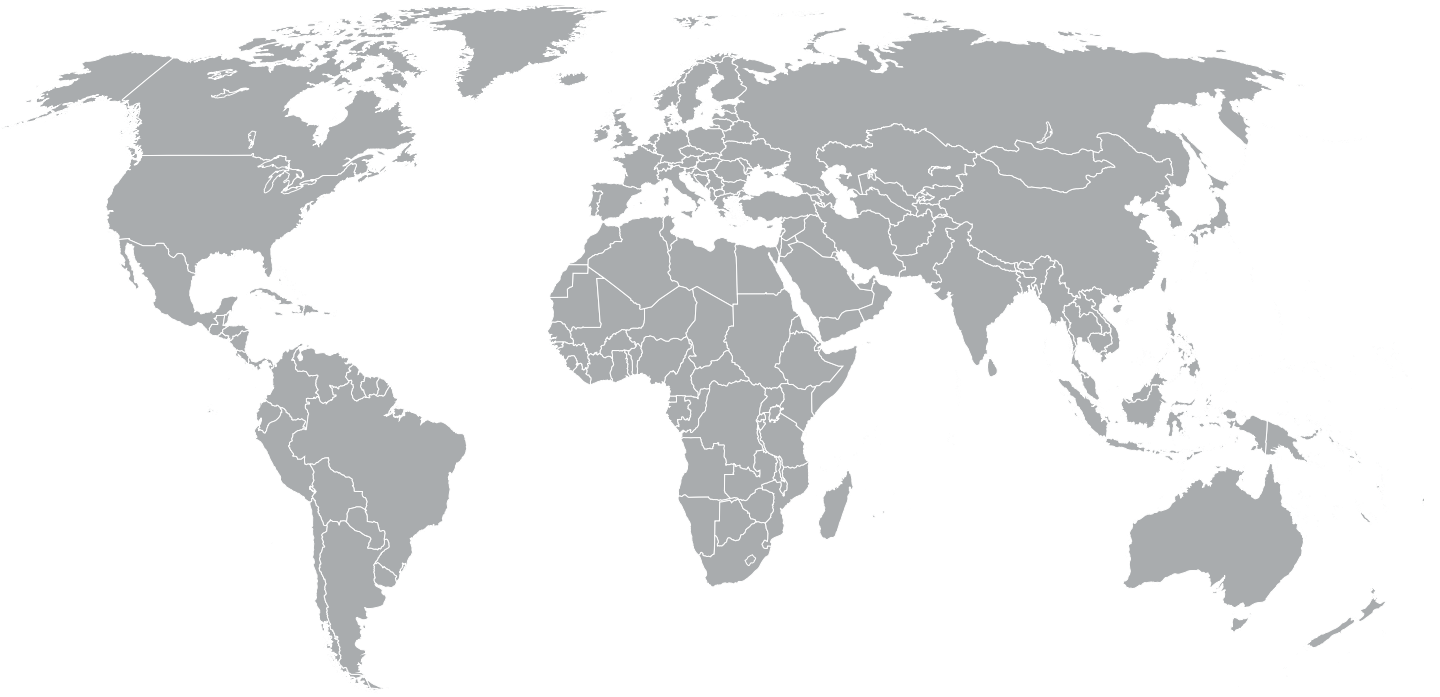

Subject to modifications

24004.029 Valid since 2021-07