

RFK Flextronic Flamcomat Pole 3 phase

ENG Retrofit Quickstart guide

Maintenance and service
Depressurise the installation and disconnect it from the power supply.

Safety requirements
The product must be earthed at all times. Installation and maintenance must be carried out by qualified personnel.

Removal
There is danger of scalding! Hot water can flow out of the system. Remove the product.

DEU Nachrüst Schnellstartanleitung

Wartung und Service
Machen Sie die Anlage drucklos und unterbrechen Sie die Stromversorgung.

Sicherheitshinweise
Das Produkt muss jederzeit geerdet sein. Montage- und Wartungsarbeiten dürfen nur durch Fachpersonal ausgeführt.

Demontage
Vorsicht, Verbrennungsgefahr! Aus der Anlage kann heißes Wasser austreten. Entfernen Sie das Produkt.



flamcogroup.com/manuals

Content Inhalt Inhoud Con

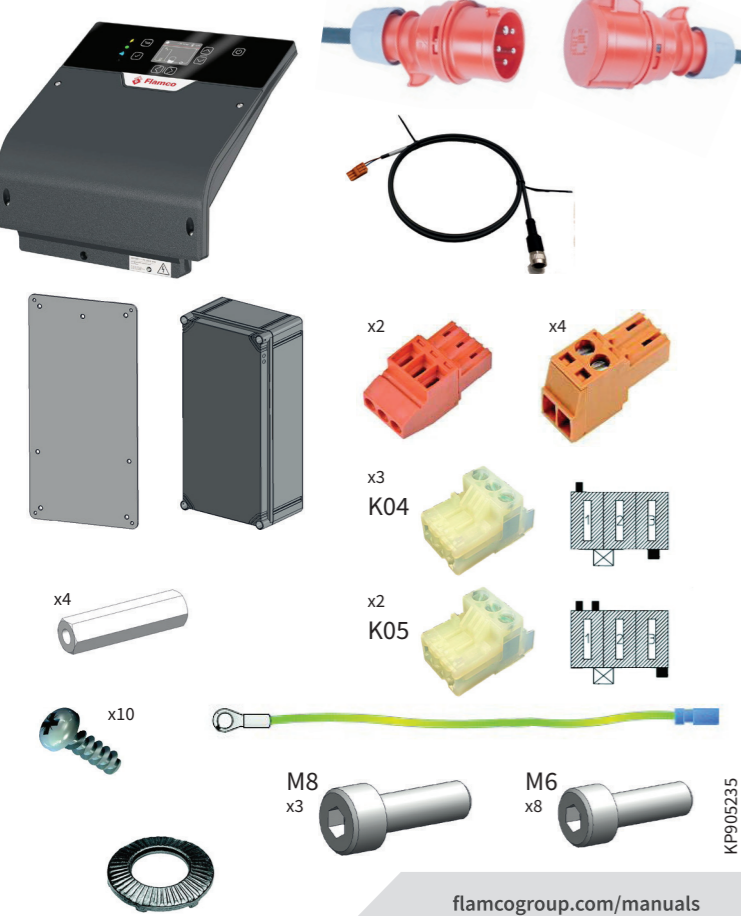

flamcogroup.com/manuals

- 1**
- Close the system valves
 - Systeem Ventile sluiten
 - SysteemKleppen sluiten
 - Fermer les vannes du Système

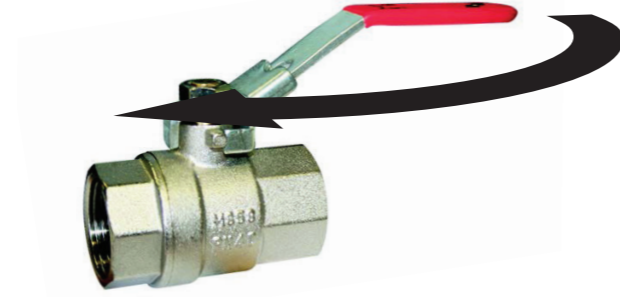

- 4**
- Remove the SPC, SPC-display and the metal bracket
 - Entfernen Sie die SPC, die SPC-Anzeige und die Metallhalterung
 - Verwijder de SPC, SPC-display en de metalen beugel
 - Retirez le SPC, l'achage SPC et le support en métal

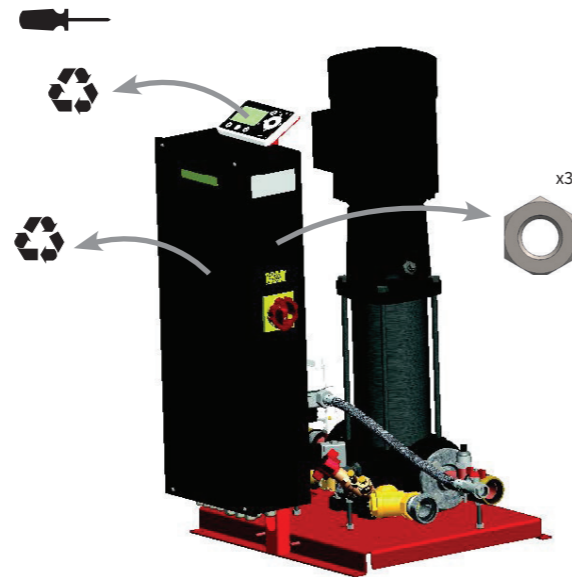

- 7**
- Connect the earth cable to the red frame at the point indicated.
 - Schließen Sie das Erdungskabel an den angegebenen Punkten an den roten Rahmen an.
 - Verbind de aardekabel met de rode beugel op de aangegeven punten.
 - Connectez le câble de terre au cadre rouge aux points indiqués.

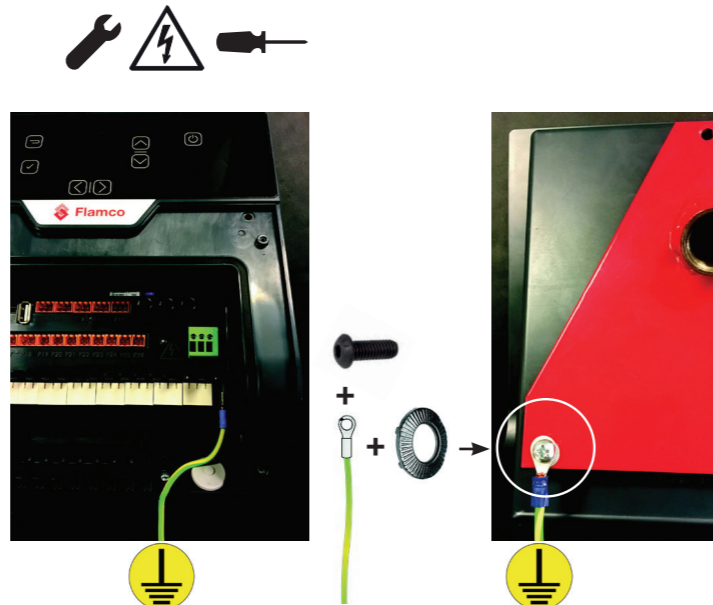

- 2**
- Drain vessel and disconnect from mains
 - Leeren Sie das Gefäß und unterbrechen Sie die Stromversorgung der Maschine
 - Vat legen en stroomtoevoer naar automaat doorbreken
 - Videz le récipient et coupez l'alimentation électrique de la machine

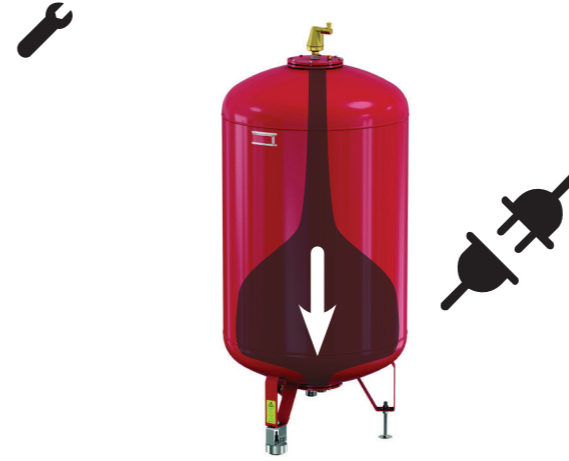

- 5**
- Install new bracket and Flextronic base on the frame.
 - Befestigen Sie den neue Metallhalterung und Flextronic am Rahmen
 - Bevestig de nieuwe metalen beugel en de Flextronic op het frame
 - Montez le support en métal et le Flextronic sur le cadre

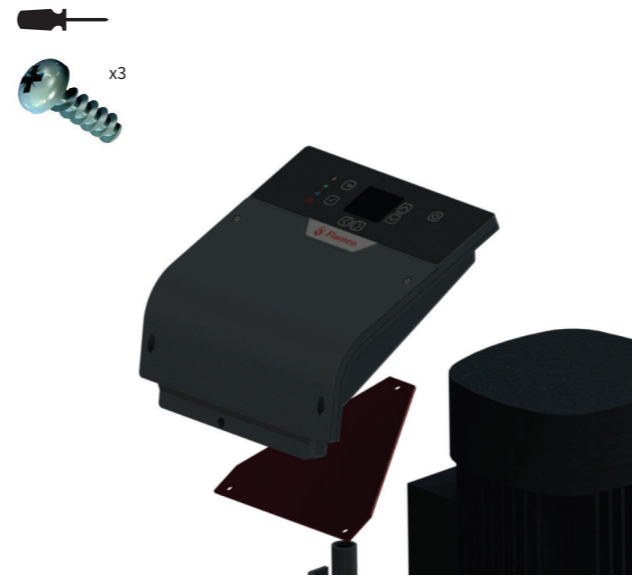

- 8**
- Connect power cable to 400V cabinet and connect mains cable to Flextronic.
 - Schließen Sie das Netzkabel an den 400-V-Schrank und das Netzkabel an die Flextronic an.
 - Sluit de stroomkabel aan op de 400V kast en sluit de mains kabel aan op de Flextronic.
 - Connectez le câble d'alimentation à l'armoire 400V et connectez le câble d'alimentation au Flextronic

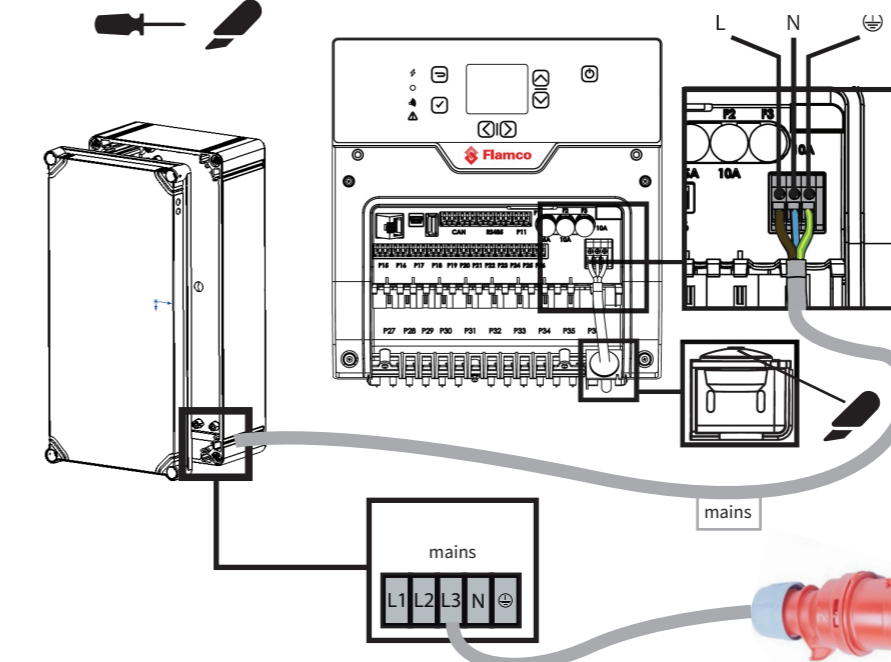

- 3**
- Disconnect the cables from the SPC controller
 - Trennen Sie die Kabel vom SPC-Controller
 - Haal de kabels van de SPC-controller los
 - Déconnecter les cables de contrôleur SPC

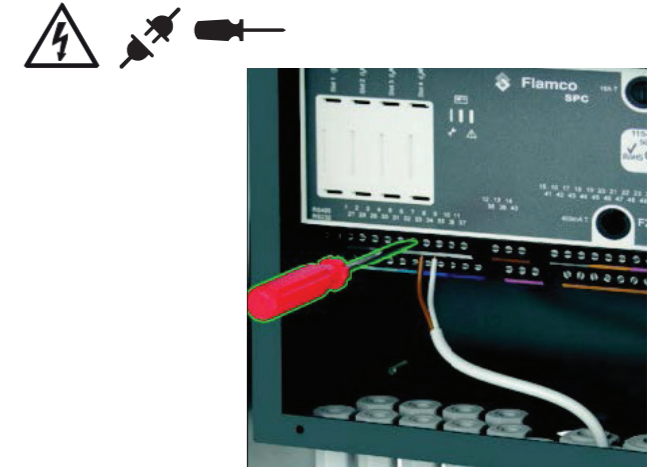

- 6**
- Install Flextronic bracket and cabinet on the pole
 - Installieren die Flextronic-Halterung und das Gehäuse an der Stange
 - Bevestig de Flextronic beugel en kast op de paal
 - Installez le support et l'armoire Flextronic sur le poteau.

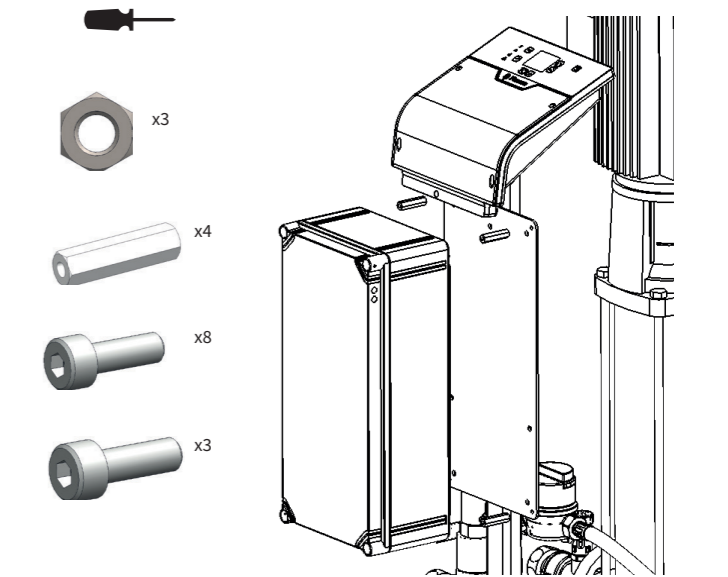

- 9**
- Install the safety connector in mains cable
 - Den Sicherheitsstecker in das Netzkabel einbauen
 - Installeer de veiligheidsstekker in de stroomkabel
 - Installez le connecteur de sécurité dans le câble d'alimentation



- 10
- Connect all connectors to the cables and plug them in the correct terminal
 - Schließen Sie alle Stecker an die Kabel an und stecken Sie sie in die richtige Klemme
 - Sluit alle connectoren aan op de kabels en steek ze in de juiste terminal
 - Connectez tous les connecteurs aux câbles et branchez-les dans le bon terminal

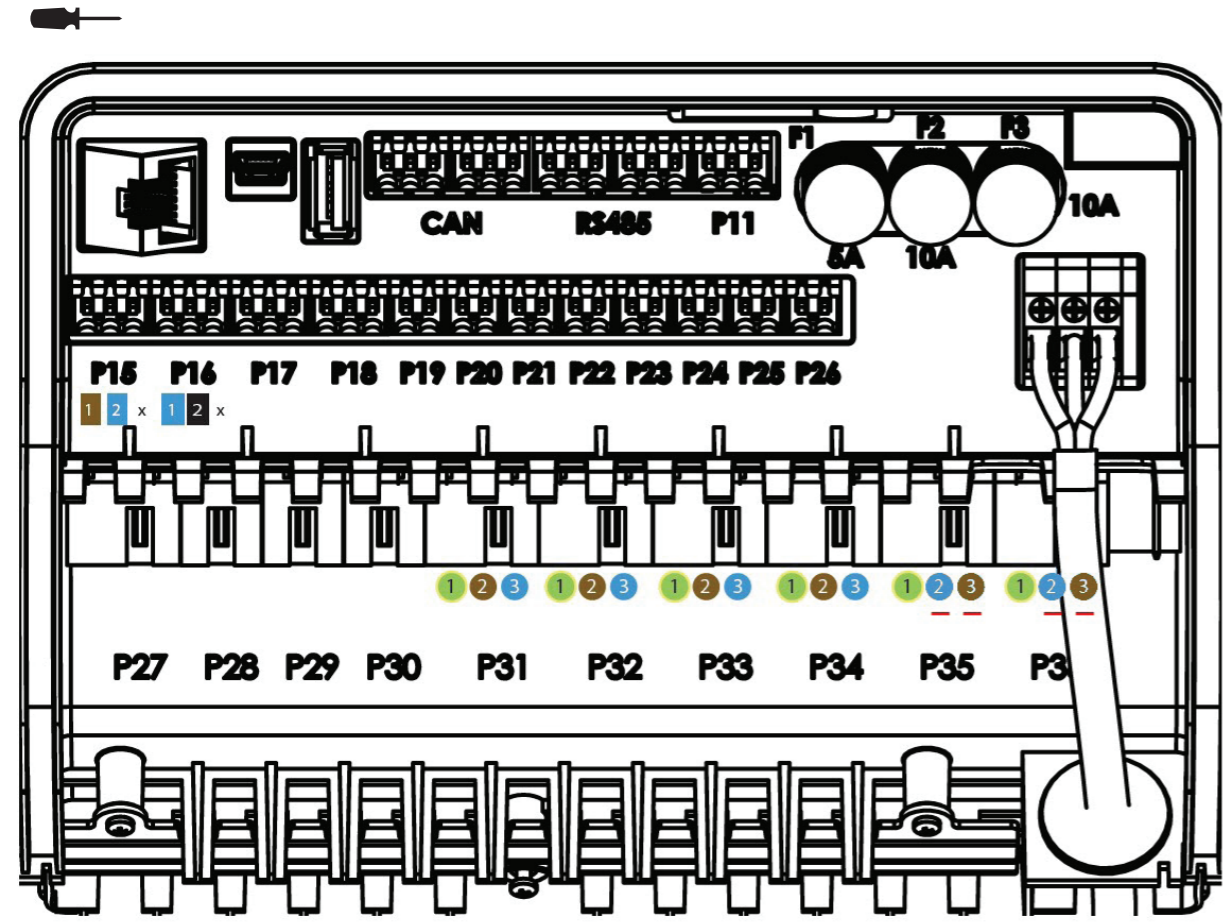

SPC	Actuator	Terminal Flextronic	Connector
2	Pressure	P15-1	orange
3		P15-2	
X		P15-3	X
4	Level	P16-1	orange
5		P16-2	
X		P16-3	X
8	PWM	P19-1	orange
9		P19-2	
12	NO fault	P27-1	white K00
13	COM	P27-2	
14	NC fault	P27-3	
27	TS	P21-1	orange
28		P21-2	
29	GS	P22-1	orange
30		P22-2	
31	DRS	P23-1	orange
32		P23-2	
10	MPL	P24-1	orange
11		P24-2	
33	PS	P25-1	orange

SPC	Actuator	Terminal Flextronic	Connector
33	PS	P25-1	orange
34		P25-2	
35	A/O Pressure	P26-1	orange
36		P26-2	
36	A/O Level	P11-3	orange
37		P11-1	
18	Refill	P31-1	white K04
19		P31-2	
20		P31-3	

- PE- Earth/ Erde/ Aarde/ Terre
- BR- Brown/ Brune/ Bruin/ Marron
- BL- Blue/ Blau/ Blauw/ Bleu
- BK- Black/ Schwartz/ Zwart/ Noir

SPC	Actuator	Terminal Flextronic	Connector
15		P32-1	
16	Drain	P32-2	White K04
17		P32-3	
41		P33-1	
42	V1	P33-2	White K04
43		P33-3	
47		P34-1	
48	V2	P34-2	White K04
49		P34-3	
21		P35-1	
22	M1	P35-2	White K05
23		P35-3	
24		P36-1	
25	M2	P36-2	White K05
26		P36-3	

- 11
- Install the pull restriction and service lid
 - Installieren Sie die Zugbegrenzung und den Wartungsdeckel
 - Monteer de trekcontlasting en onderhoudskap
 - Installer la restriction de traction et le couvercle de service

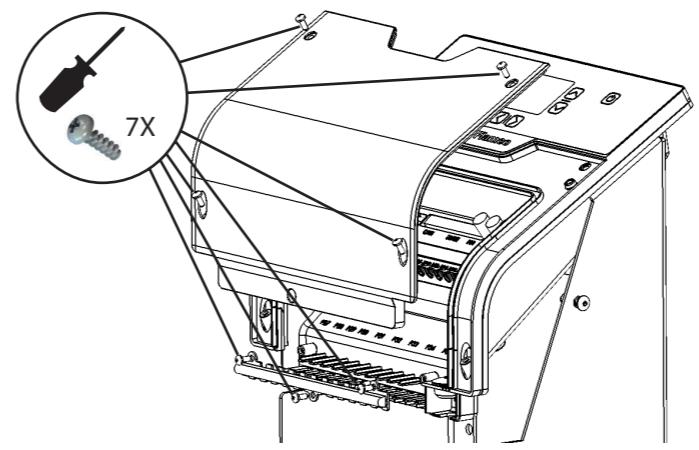

- 12
- Connect the power cord and activate the machine
 - Schließen Sie das Netzkabel an und aktivieren Sie das Gerät
 - Sluit de stroomkabel aan en activeer de automaat
 - Branchez le cordon d'alimentation et allumez la machine

